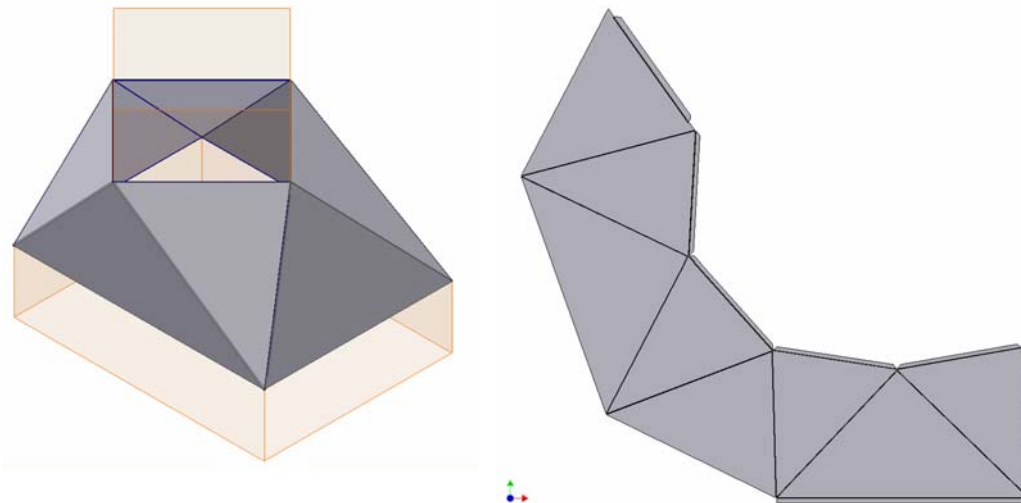


## Module 5: Creating Sheet Metal Transition Piece Between a Square Tube and a Rectangular Tube with Triangulation

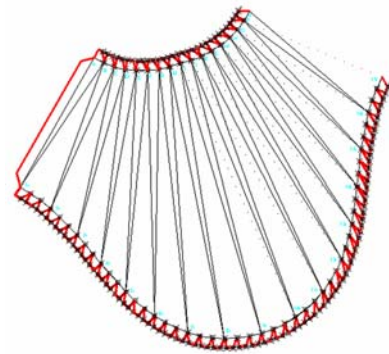
In Module 5, we will learn how to create a 3D folded model of a sheet metal transition piece between a square tube on top and a rectangular tube at the bottom, both at an angled or “twisted position” as shown on *Figure 5-1A*, by triangulation, without using a Derived Part of a 3D solid model for its Work Surface as explored in Module 5B, but directly in the creation of a sheet metal part wrapping the 3D space, which is defined by a wire-frame 3D model composed of profile sketches drawn on several Work Plane features defined by three points. “Triangulation” is the process of using triangles of various sizes and configurations as the basic geometric shapes, or the fundamental building blocks for 3D modeling, in the creation of regular or irregular 3D surfaces (*Figure 5-1B*), or as a transition element connecting curved or straight edges, as a way to decompose irregular warped 3D surfaces into developable 2D flat patterns (*Figure 5-1C*).



*Figure 5-1A: The transition piece folded model (left) and flat pattern (right).*



*Figure 5-1B: The warped surface of this animal's face is based on polygons that can be considered as further divisible into triangles (created in 3D Studio MAX).*



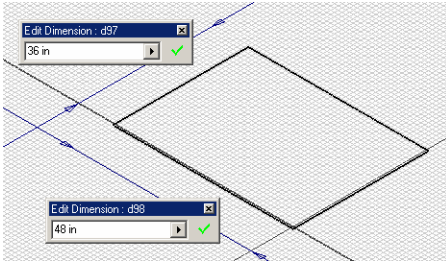
*Figure 5-1C: Triangulation used in the flat pattern of the warped surface of a transition piece between two cylindrical tubes positioned on different axis.*

### ***Step 1: Creating the top and base of the wire-frame 3D model***

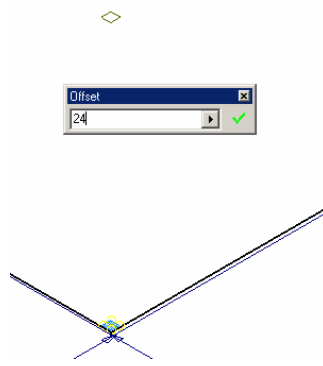
Launch Inventor, start a new **Sheet Metal (in).ipt** file under **English** tab. Turn **Visibility** on for the **XZ Plane**. “*Sketch1*” is created by default in the **Model** panel's **XY Plane** (the one parallel to your computer's screen); click the **Return** button to exit the **Sketch** mode; and delete the default *sketch1* feature from the **Model** panel with the **Delete** key on the keyboard. Select the **XZ Plane** in the **Model** panel and click the **Sketch** button to start a new sketch; rename it *Base Profile* in the **Model** panel; use the **Rectangle** and **General Dimension** tools to draw a 36 x 48 (inches) rectangle (*Figure 5-2A*); click the **Return** button to exit the **Sketch** mode. Save the file as *Tut-Twisted Rec and Square Transition.ipt*. Save often throughout the entire project.

Next, use the **Work Plane** tool to create a work plane parallel to and 24 inches above the **XZ Plane**, and rename it *Top Profile Work Plane* in the **Model** panel (*Figure 5-2B*); select this plane and click the **Sketch** button to start a new sketch; and rename it *Top Profile* in the **Model** panel (*Figure 5-2C*); click the **Look At** button and the *Top Profile Work Plane* to switch to an orthographic view, use the **Project Geometry** tool to project the lower horizontal edge and the right vertical edge of the rectangle on the *Base Profile* sketch onto the current sketch; next, use the **Polygon** tool with **Inscribed** and **4** side option to draw a square which sides appear to be 45° to horizontal; and use the **General Dimension** tool to apply a 24-inch length to the sides of the square, and a 45-degree angle between one side of the square and the projected horizontal edge line of the rectangle, and a 6-inch distance between the right corner of the square and the projected right vertical edge of the rectangle, and between the lower corner of the square and the

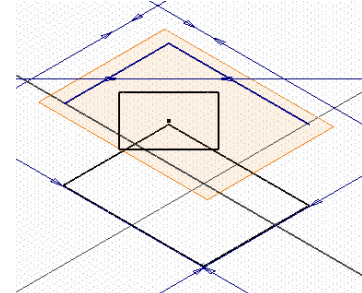
projected lower horizontal edge of the rectangle (*Figure 5-2D*); click the **Return** button to exit the sketch. The *Top Profile* and *Base Profile* used to generate the wire-frame 3D model are complete (*Figure 5-2D*). Go to **View**→**Isometric** menu to switch to **Isometric** view for better visualization.



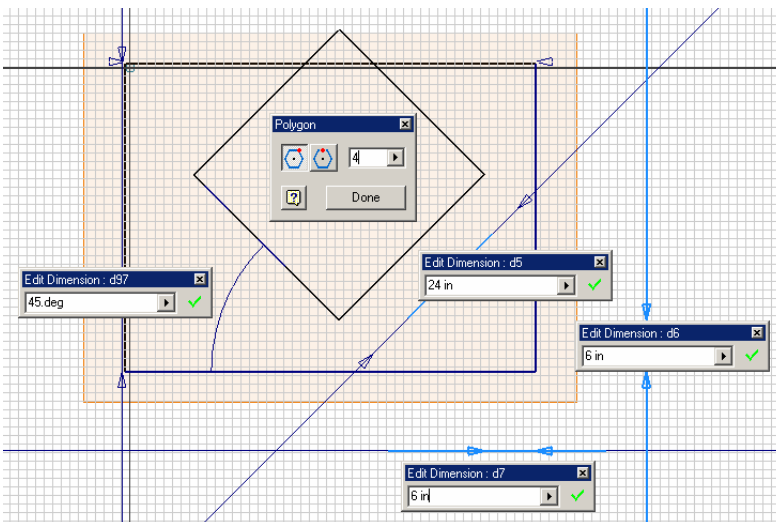
*Figure 5-2A: The 36 x 48 (inches) rectangle.*



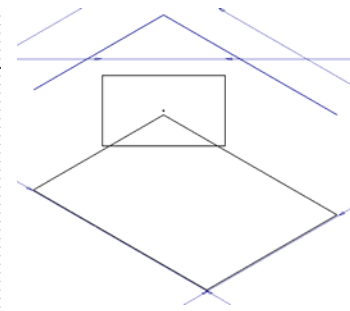
*Figure 5-2B: The Top Profile Work Plane.*



*Figure 5-2C: The Top Profile sketch.*



*Figure 5-2D: The completed Top Profile.*

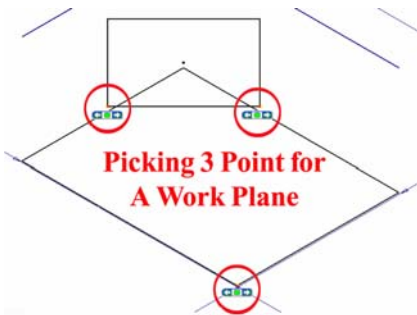


*Figure 5-2E: The completed Top Profile and Base Profile.*

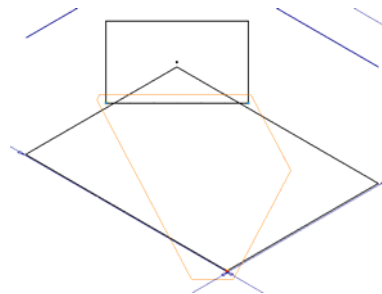
**Step 2: Creating work planes defined by three points and drawing triangle profiles on the planes**

Select the **Work Plane** tool; move the cursor closer to the lower (front) corner of the top square, click once at the appearance of the red dot snap indicator; repeat this step with the right corner point of the top square and then the lower right corner of the

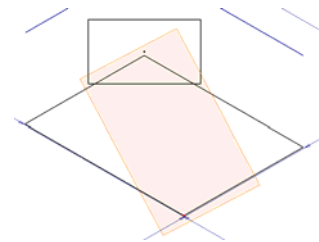
rectangle (as shown in *Figure 5-3A*. The order of selection does not matter); a temporary orange **Work Plane** feature indicator appears before the third point (at the lower right corner of the rectangle) is clicked (*Figure 5-3B*); the new **Work Plane** feature is created (*Figure 5-3C*); rename it *Front Right Inverse Triangle Work Plane* in the **Model** panel. Next, select the new *Front Right Inverse Triangle Work Plane* and click the **Sketch** button to start a new sketch; and rename it *Front Right Inverse Triangle Sketch* in the **Model** panel; use the **Project Geometry** tool to project the lower-right edge of the Square and the lower-right corner of the rectangle (*Figure 5-3D*); then use the **Line** tool to add two additional edge lines to complete the triangle (*Figure 5-3E*); then click the **Return** button to exit the sketch; and uncheck the Visibility option of the *Front Right Inverse Triangle Work Plane* in the **Model** panel, so as to avoid visual confusion. As is shown on *Figure 5-3F*, the transition piece is composed of four upward-pointing base triangles and four downward-pointing top inverse triangles. Repeat the same basic process with some minor modifications as shall be explained in the next paragraphs to create additional work planes and triangle sketches, and rename them with specific names as shown on *Figure 5-3G*.



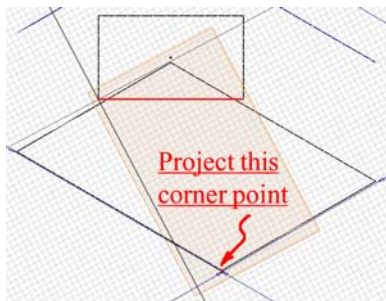
*Figure 5-3A: Picking the three points to create a work plane.*



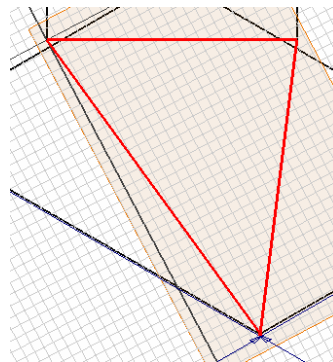
*Figure 5-3B: The temporary work plane indicator.*



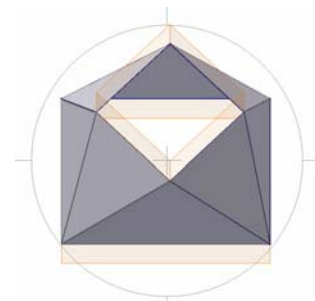
*Figure 5-3C: The new work plane created.*



*Figure 5-3D: projecting the lower-right edge of the Square and the lower-right corner of the rectangle.*

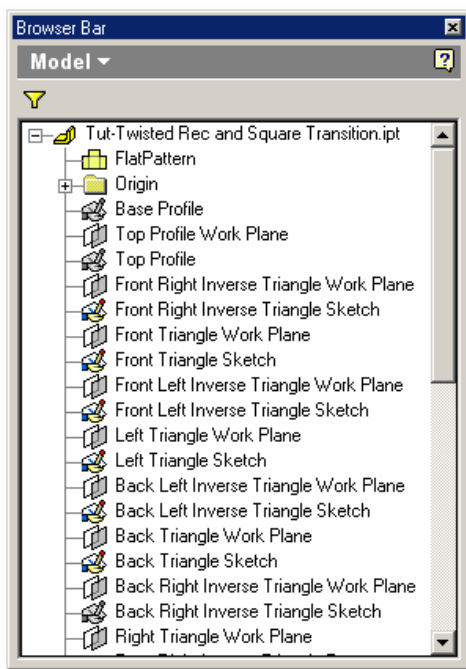


*Figure 5-3E: Adding two additional edge lines to complete the triangle.*

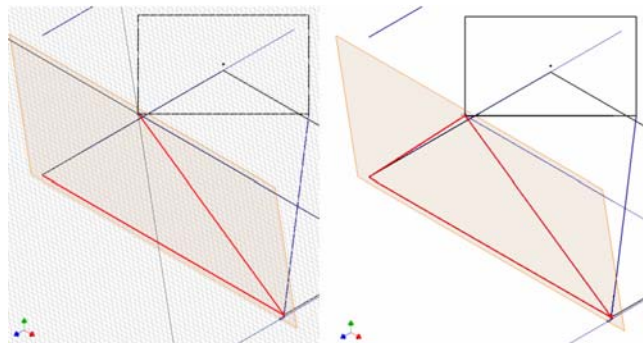


*Figure 5-3F: The upward-pointing base triangles and the downward-pointing top inverse triangles.*

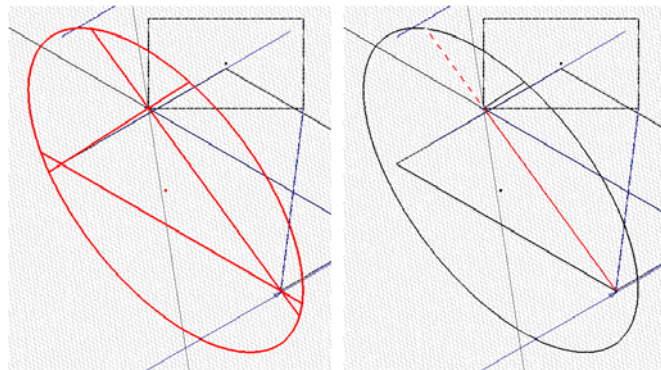
In creating the 2<sup>nd</sup>, 3<sup>rd</sup>, 4<sup>th</sup> through 8<sup>th</sup> triangle profile sketches, project one edge line from the *Top Profile* or *Base Profile*, one edge line from the previous triangle profile; and draw a third edge line to complete the new triangle profile sketch (*Figure 5-3H*). In addition, to prevent “open loop” problems when using projected edge line, sometimes it is a good idea to change all projected lines’ **Style** to **Normal**; and then apply the “**Circle-Extend-Trim**” method (using the **Circle** tool to draw a big circle enclosing the triangle shape; use the **Extend** tool to extend all edge lines to the circle; use the **Trim** tool to trim off all unneeded line segments to return to the basic triangle; and remove the circle with the Delete key in the keyboard, as shown in *Figure 5-3I*).



*Figure 5-3G: The **Model** panel with a list of the work planes and triangle sketches.*



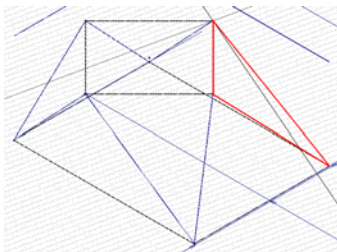
*Figure 5-3H: Projected edge line from the *Top Profile* or *Base Profile*, and from the previous triangle profile (left); third edge line drawn (right).*



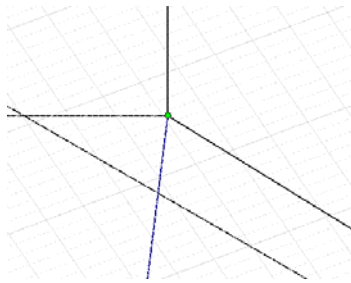
*Figure 5-3I: The “Circle-Extend-Trim” method.*

In creating the 7<sup>th</sup> triangle sketch (the *Back Right Inverse Triangle*, shown in *Figure 5-4A*), notice that its top left corner is touching the top right corner of the first triangle (the *Front Right Inverse Triangle*); this is perfectly workable in the real world;

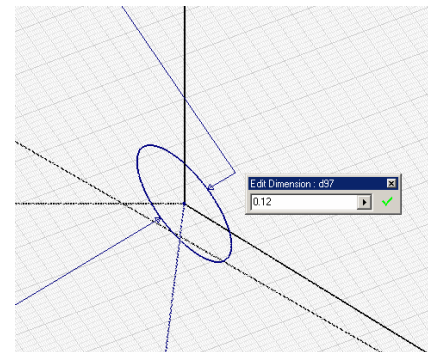
however, in Inventor, it might cause problems in generating a flat pattern because without a “gap” or opening between the first and the last Face panels, Inventor has no way to determine where to start the flat pattern projection; therefore, provide a “corner relief” or a cutoff at this touching corner. Use the **Project Geometry** tool to project the corner point onto the sketch (*Figure 5-4B*) for a snap point; then use **Center Point Circle** tool to draw a circle centered at the projected corner point (*Figure 5-4C*); use the **General Dimension** tool to apply a 0.12-inch diameter (the 0.12-inch value here equals the thickness of the intended sheet metal material) to the circle (*Figure 5-4C*); change the **Style** of projected edge line to **Normal** for trimming, and use the **Trim** tool to trim off all unneeded line and arc segments (*Figure 5-4D*); delete the projected corner point with the **Delete** key on the keyboard; next, as a measure to prevent “open loop” problem, apply the “**Circle-Extend-Trim**” method to the other two corners of the triangle before exiting the sketch.



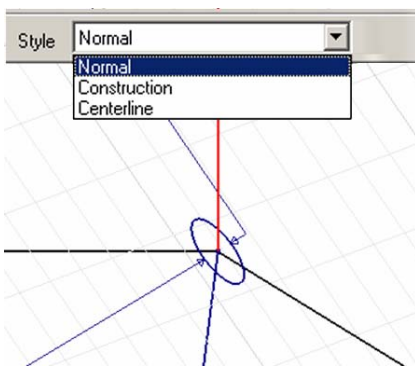
*Figure 5-4A: The Back Right Inverse Triangle.*



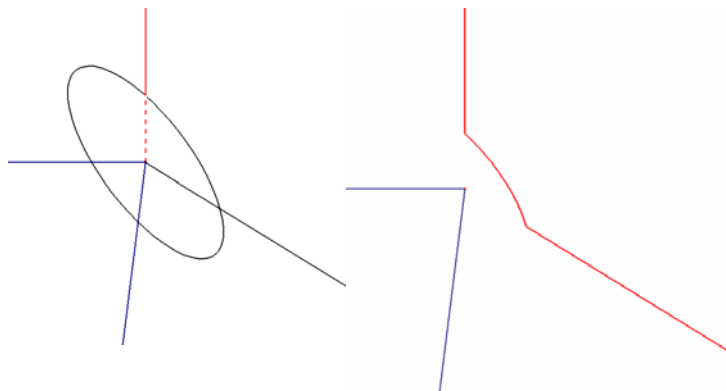
*Figure 5-4B: The projected corner point.*



*Figure 5-4C: Applying a 0.12-inch diameter to the circle.*

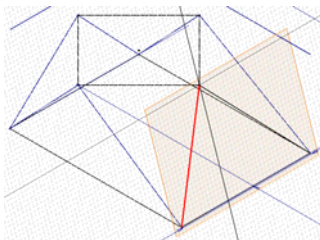


*Figure 5-4D: Changing the Style of the projected edge line to Normal for trimming.*

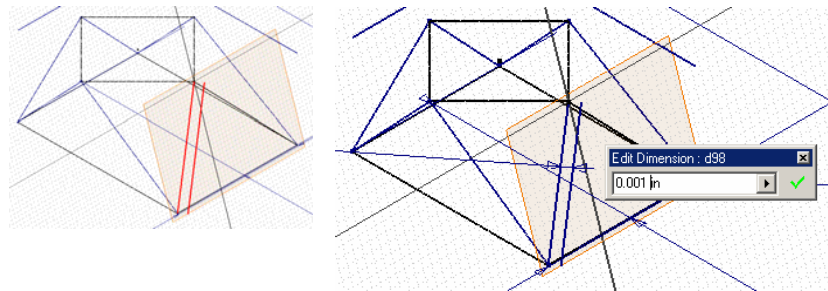


*Figure 5-4E: Trimming the lines (left) to the final profile (right).*

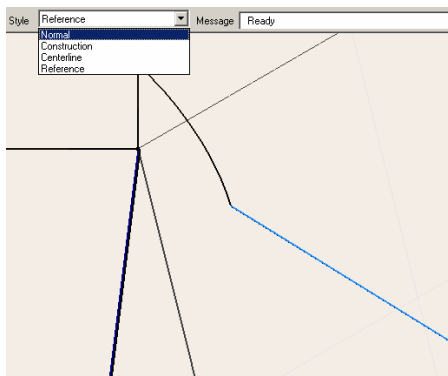
In creating the 8<sup>th</sup> triangle sketch (the *Right Triangle Sketch*), first use the **Project Geometry** tool to project the right edge line of the first triangle sketch (the *Front Right Inverse Triangle Sketch*), which is the lateral seam edge in the flat pattern (*Figure 5-5A*); use the **Offset** tool to draw an offset line on the side of the 8<sup>th</sup> triangle sketch, and use the **General Dimension** tool apply with an **Aligned** option to apply a 0.001-inch aligned dimension for the gap (*Figure 5-5B*); then delete the projected edge line with the **Delete** key on the keyboard; next, use the **Project Geometry** tool to project the right edge line of the 7<sup>th</sup> triangle sketch; and change its line **Style** to **Normal** (*Figure 5-5C*); use the **Extend** tool to extend it to the first offset edge line; and use the **Trim** tool to trim off the excessive segment of the first offset line (*Figure 5-5D*). Next, provide the “corner relief” on this sketch and complete all three corners of the triangle as explained in the next paragraph.



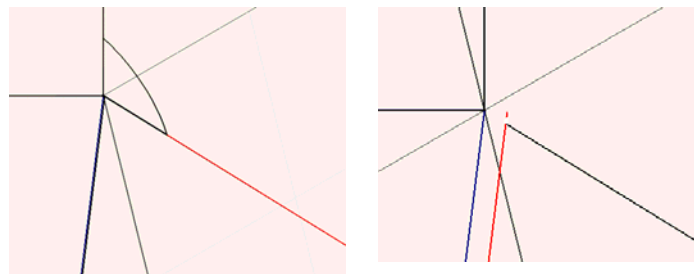
*Figure 5-5A:*  
Projected right edge  
line of the first  
triangle sketch.



*Figure 5-5B: Offset line and dimension.*

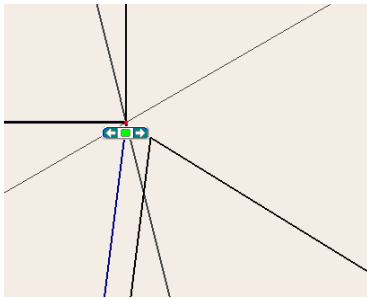


*Figure 5-5C: Projecting the edge  
line of the 7th triangle sketch and  
changing its line Style to Normal.*

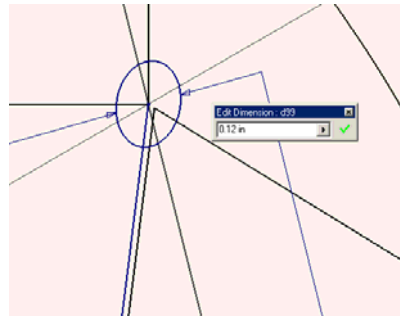


*Figure 5-5D: Extending and trimming.*

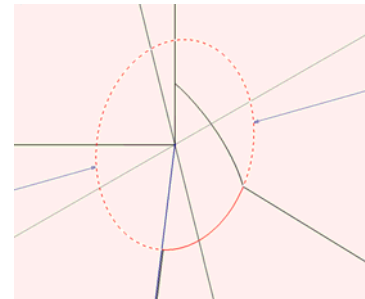
Use the **Project Geometry** tool to project the top-right corner of the first triangle sketch (the *Front Right Inverse Triangle Sketch*) as shown in *Figure 5-5E*; use the **Circle Center Point** tool to draw a circle centered at the projected corner point and apply a 0.12 diameter dimension with the **General Dimension** tool (*Figure 5-5F*); next, use the **Trim** tool to trim off excessive line segments (*Figure 5-5G*), so as to complete the profile at the top corner of the triangle (*Figure 5-5H*). Next, move to the lower-left corner of the triangle; complete the profile at the lower left corner of the triangle by projecting the edge line from the *Base Profile* sketch with the **Project Geometry** tool; changing line **Style** to **Normal** and trimming (*Figure 5-5I*). Next, move to the lower-right corner of the triangle; use the “**Circle-Extend-Trim**” method at the lower-right corner of the triangle to avoid “open loop” problem and complete the profile at the lower-right corner of the triangle (*Figure 5-5J*). The wire-frame 3D model is completed (*Figure 5-5K*).



*Figure 5-5E: Projecting the corner point.*



*Figure 5-5F: The “corner relief” circle.*



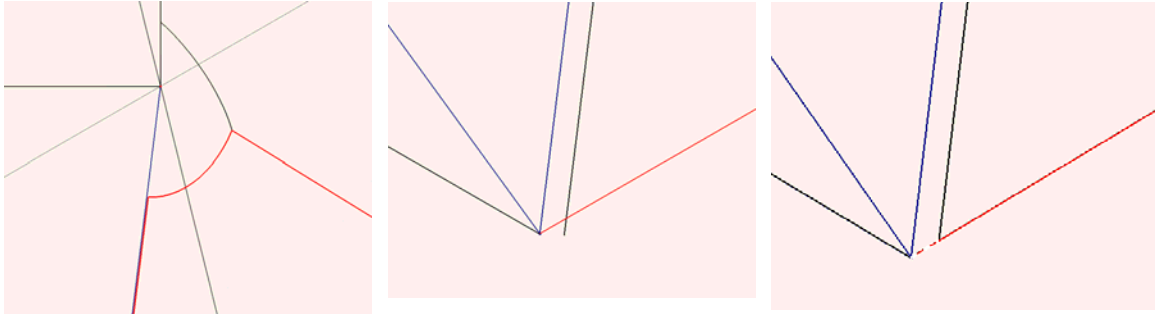
*Figure 5-5G: Trimming off excessive line segment.*

### **Step 3: Creating the triangular Face panels**

Select the Sheet Metal panel's **Styles** tool; in the **Sheet Metal Styles** dialog window that opens, under the **Sheet** tab, the default value for **Thickness** is 0.12 inch; accept the default by clicking the **Done** button (*Figure 5-6A*).

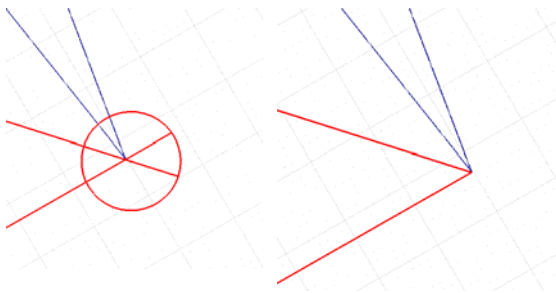
Next, create the triangular panels of the sheet metal part with the **Face** tool with the triangle sketches as **Profiles**, in the chronological order from 1<sup>st</sup> through the 8<sup>th</sup> piece, and with the **Offset** direction always pointing outward of the interior 3D space of the folded model. Use the **Rotate**, **Zoom**, **Zoom All**, and **Zoom Window** tools to help visualizing when completing the **Face** extrusion operation (*Figure 5-6B* through *Figure 5-6I*). Notice that Inventor program can automatically create a **Bend** feature between to touching **Face** panels, when and after the 2<sup>nd</sup> Face panel is created (*Figure 5-6C*), which is also automatically listed in the **Model** panel.



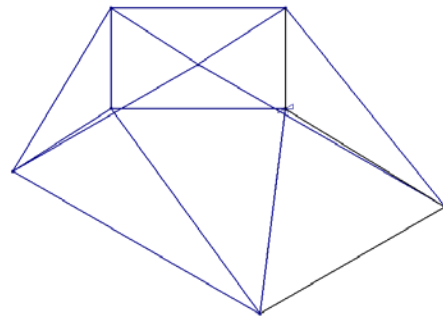


*Figure 5-5H: The complete profile at the top corner.*

*Figure 5-5I: Completing the profile at the lower left corner of the triangle by projecting the edge line from the Base Profile sketch (left); changing line **Style** to **Normal** and trimming the excessive line segments (right).*



*Figure 5-5J: Using the “**Circle-Extend-Trim**” method at the lower-right corner of the triangle to avoid “open loop” problem (left); the completed profile at lower-right corner (right).*



*Figure 5-5K: The complete wire-frame 3D model.*

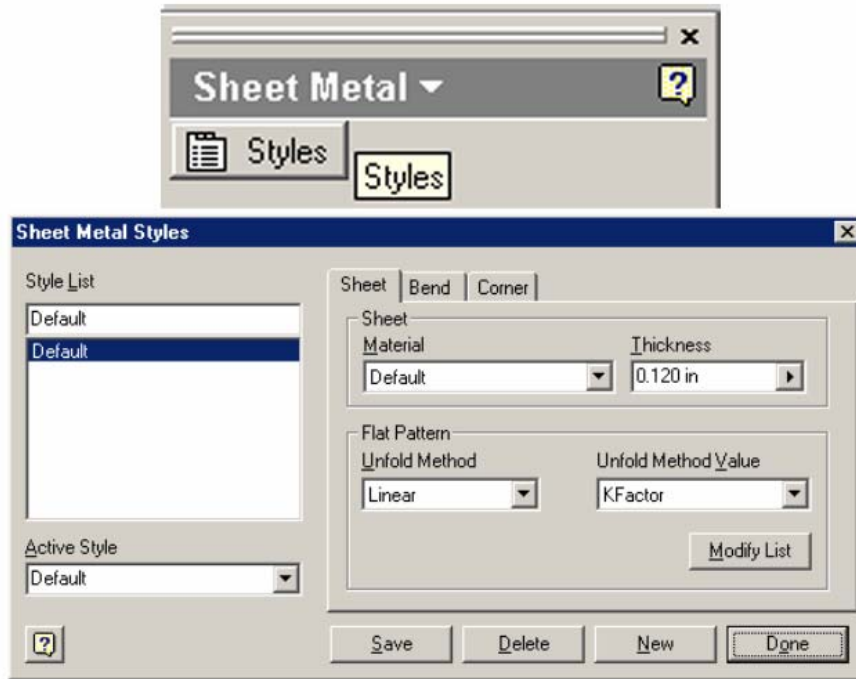


Figure 5-6A: The *Sheet Metal Styles* window.

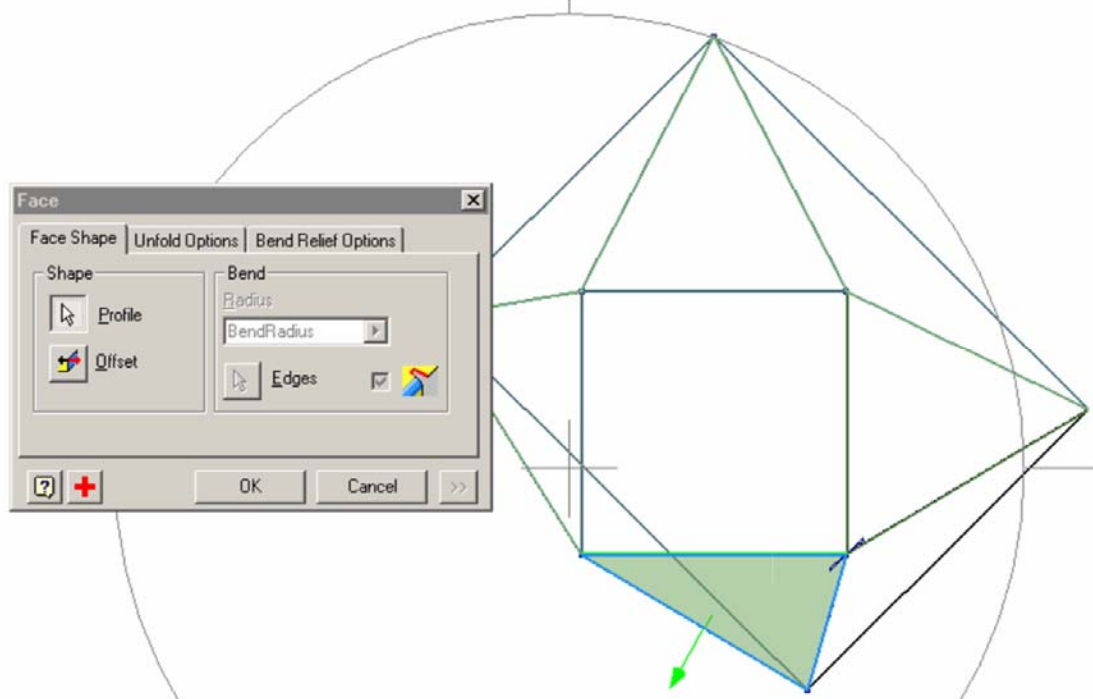
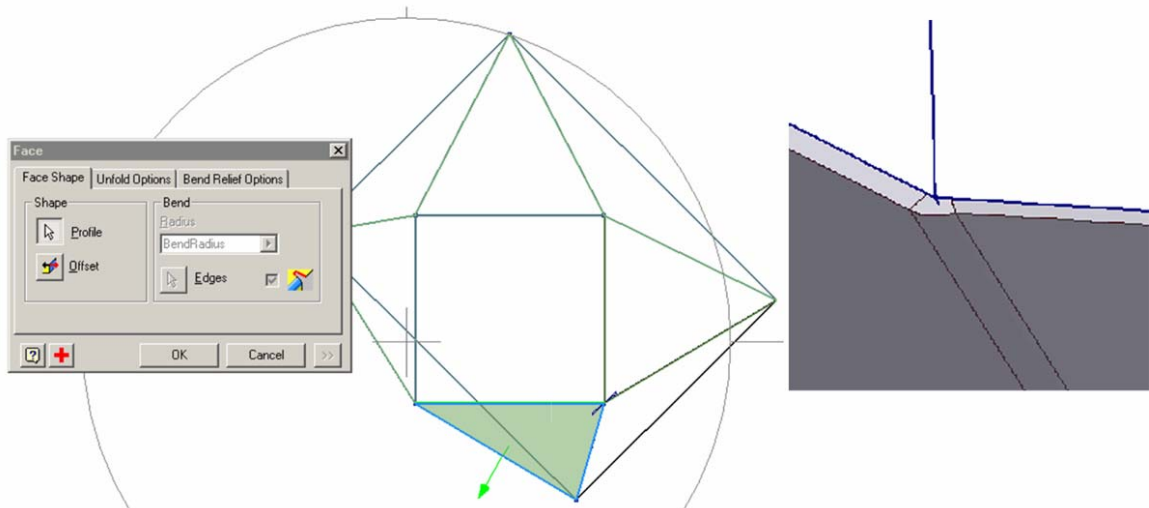
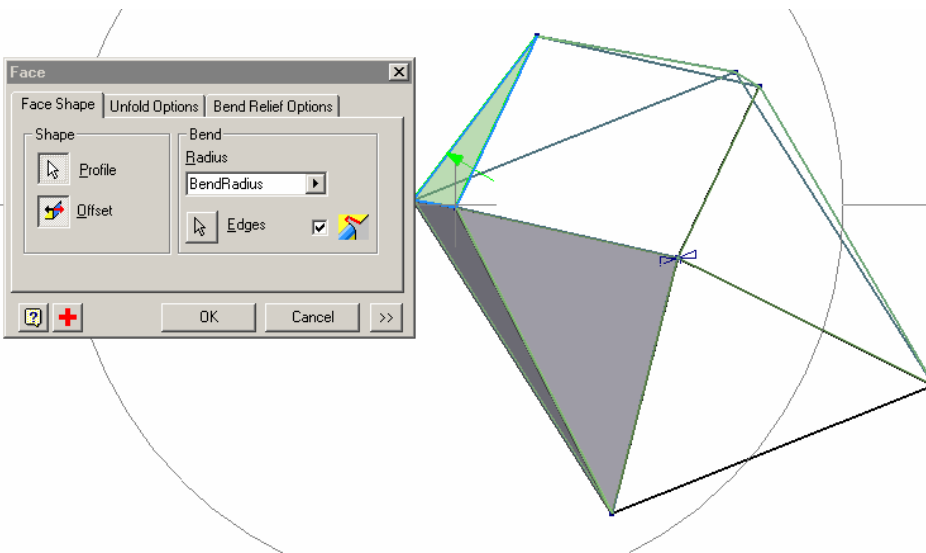


Figure 5-6B: Creating the 1<sup>st</sup> panel.

After the completion of each triangular panel, rename the respective **Face** feature with a specific name that corresponds to its related **Work Plane** and **Sketch** features names, as shown in *Figure 5-6L*. The basic part of this triangulation project with four upward-pointing triangular panels connecting the rectangular tube at the bottom and four inverse downward-pointing triangular panels connecting the square tube on the top, at a “twisted” position relative to the base tube, is therefore completed (*Figure 5-6J*).



*Figure 5-6C: Inventor program automatically creates a bend between to touching Face panels, when and after the 2<sup>nd</sup> Face panel is created.*



*Figure 5-6D: The 3<sup>rd</sup> Face panel.*

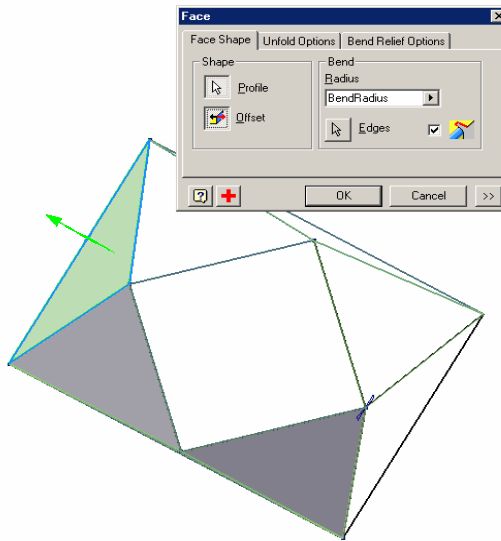


Figure 5-6E: The 4<sup>th</sup> **Face** panel.

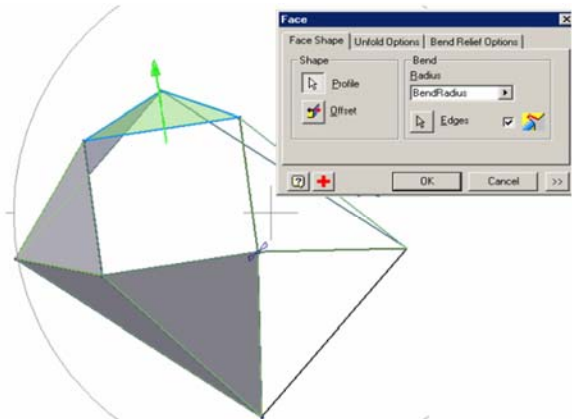


Figure 5-6F: The 5<sup>th</sup> **Face** panel.

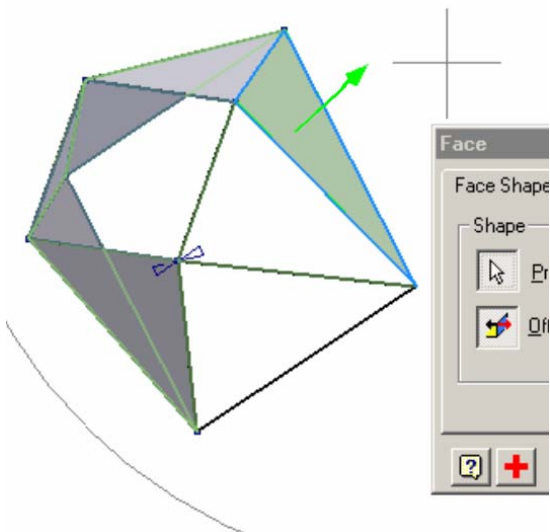


Figure 5-6G: The 6<sup>th</sup> **Face** panel.

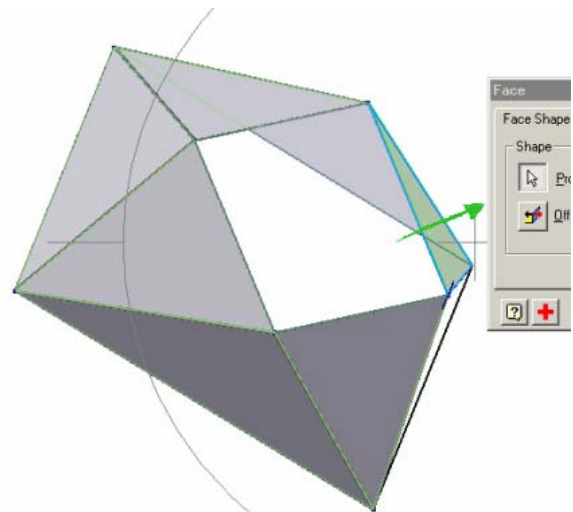


Figure 5-6H: The 7<sup>th</sup> **Face** panel.

**Step 4: Adding the lateral seam Flange and creating the flat pattern**

First, create the flat pattern to view the result of your project so far. Select the front base triangular panel of the completed transition piece (Figure 5-6J), and click-select the **Flat Pattern** tool to create and view the flat pattern projection (Figure 5-6K). Notice that in the **Flat Pattern** window, the 1<sup>st</sup> triangular panel that is click-selected before clicking the **Flat Pattern** tool button is in a right side up position (the Inventor program projects the selected surface in the most “normal” position of its own choice).

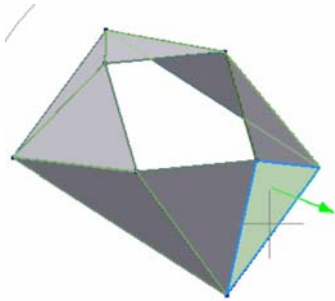


Figure 5-6I: The 8<sup>th</sup> Face panel.

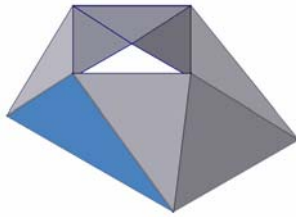


Figure 5-6J: Selecting the front base triangular panel of the completed transition piece for flat pattern projection.

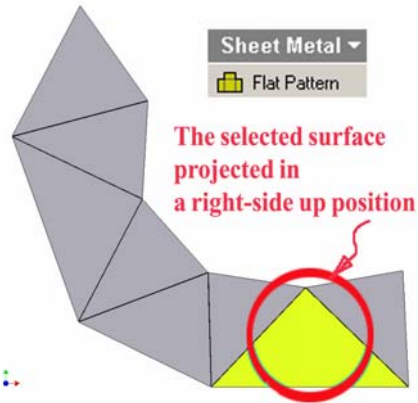


Figure 5-6K: The Flat Pattern.

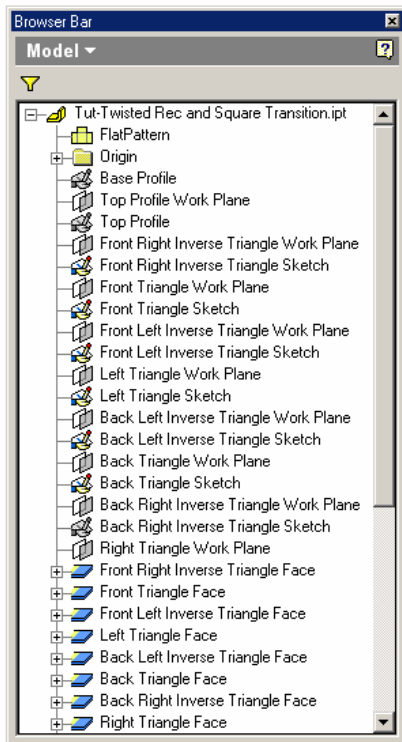


Figure 5-6L: The Model panel features created so far.

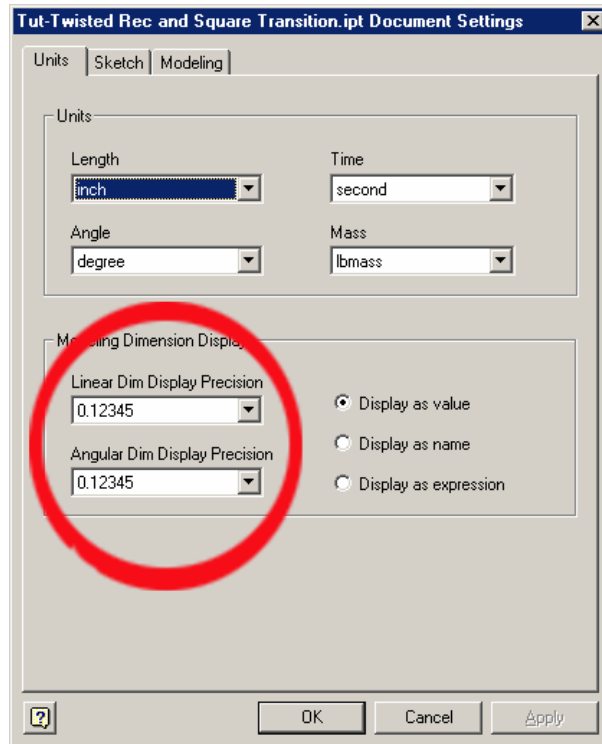
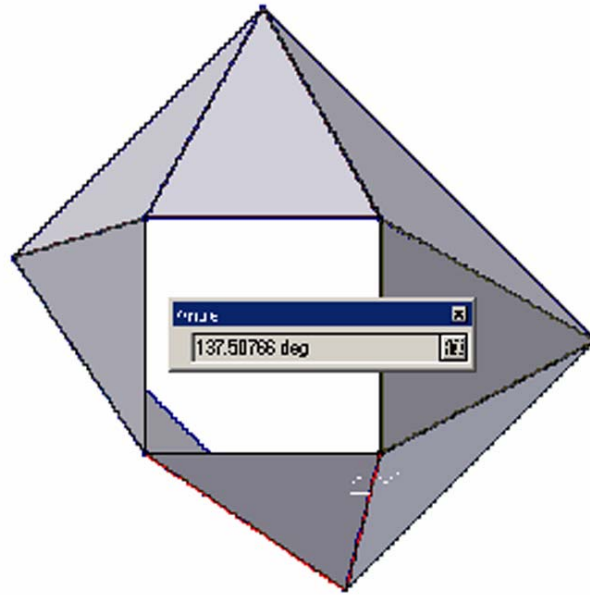


Figure 5-6M: The Document Settings window.



*Figure 5-6N: Measuring the dihedral angle between the 1<sup>st</sup> and 8<sup>th</sup> Face panels.*

Next, add the lateral seam **Flange** feature on the 8<sup>th</sup> **Face** panel that will allow it to connect the 1<sup>st</sup> panel. First, go to the **Tools**→**Document Settings** menu to open the **Document Settings** dialog window, and choose the highest possible accuracy in the **Angular Dim Display Precision** text field (*Figure 5-6M*); go to the **Tools**→**Measure Angle** menu to select the Measure Angle tool, measure the dihedral angle between the two Face panels by click-selecting the outer surfaces of the 1<sup>st</sup> and 8<sup>th</sup> Face panel features (*Figure 5-6N*); the **Measure Angle** text field read 137.50766 degree; however, as already explained in previous *Modules* such as *Module 4B*, the angle for the Flange to bend up is 180-137.50766 degrees. Use the **Rotate** tool to rotate the 3D model to a position similar to *Figure 5-7A*; use the **Zoom Window** tool several times to enlarge the windowed area (*Figure 5-7B*), so that the gap between the 1<sup>st</sup> and 8<sup>th</sup> **Face** panels can be seen; next, select the **Flange** tool, click the arrow button right under **Shape** section name and click-select the inner edge of the 8<sup>th</sup> panel (*Figure 5-7C*); next, type 1 (inch) in the **Distance** text field and 180-137.50766 in the **Angle** text field of the **Shape** section; click the >> button at the lower right corner of the default **Flange** dialog window to open the **Extents** section, choose **Offset** type from the **Type** pull-down menu, and type 2 (inch) for both **Offset1** and **Offset2** text fields (*Figure 5-7D*); next, click the arrow button on the left of the **Offset1** text field, move the cursor to a corner point of the selected edge line and click once at the appearance of the endpoint snap indicator; the arrow button to the left of **Offset2** text field is now automatically selected and appears as recessed; move the cursor to the other corner point of the selected edge line and click once at the appearance of the endpoint snap indicator; the green **Flange** feature's geometry outline appears with an

arrow pointing to the **Flip Offset** direction; it should be pointing towards the interior of the 3D space; if not, then click the **Flip Offset** button to the right of the arrow button right under the Shape section name to change its direction; in addition, the **Flange** feature should be projected inwardly from the 8<sup>th</sup> **Face** panel towards the 1<sup>st</sup> **Face** panel; if not, then click the **Flip Direction** button to the right of the **Distance** text field to change the direction (*Figure 5-7D*). Use the **Rotate** and **Zoom Window** tools to rotate the model to a visually convenient position, and to enlarge the view, such that the green outlines of the flange's geometry indicate that the ends of the flange are not interfering with other parts of the model (if not, then increase the value of **Offset1** and/or **Offset2**, as shown in *Figure 5-7D*), and that the **Flange** feature projected from the 8<sup>th</sup> **Face** panel appears to be inside of the 1<sup>st</sup> **Face** panel it is intended to be connecting (*Figure 5-7E*); click the **OK** button to create the **Flange** feature after a satisfactory visual checkup; and rename the **Flange** feature *Right Triangle Lateral Flange* in the **Model** panel. Next, apply 0.75-inch **Corner Chamfers** to both ends of the *Right Triangle Lateral Flange*; and rename the **Corner Chamfers** feature *Right Triangle Lateral Flange Chamfers* in the **Model** panel (*Figure 5-7F*).

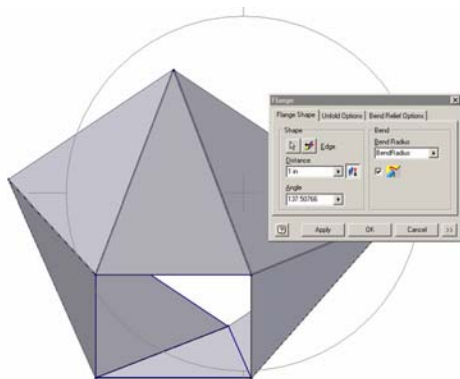


Figure 5-7A: Rotating the model.

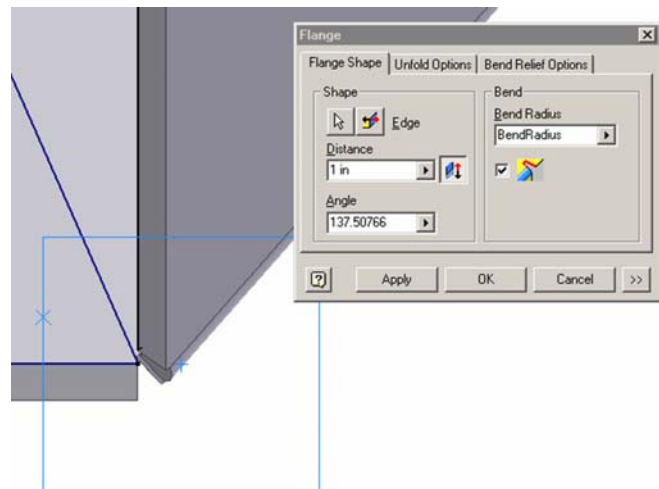


Figure 5-7B: Window zooming.

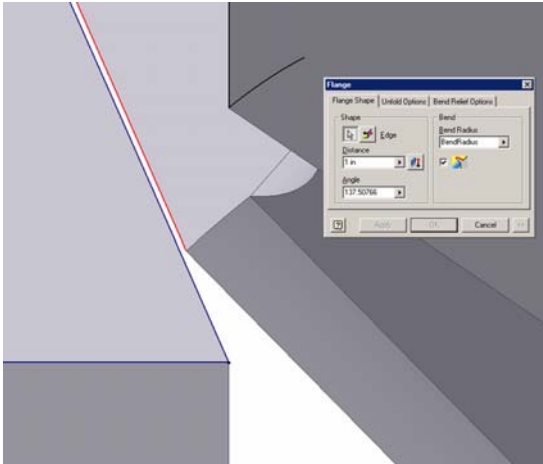


Figure 5-7C: Selecting the **Edge** for the **Flange** feature.

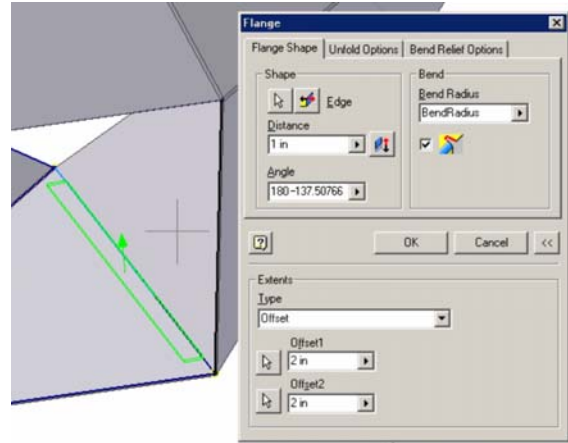


Figure 5-7D: The **Flange** tool dialog window settings; and visual checkup for non-interference of the **Flange** feature relative to other parts of the model.

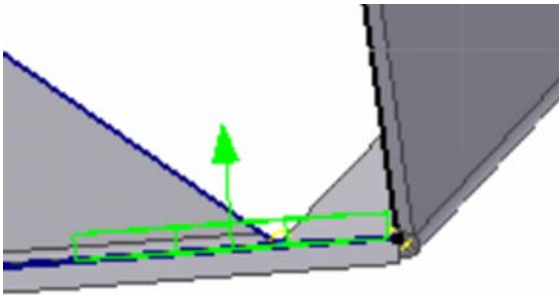


Figure 5-7E: Visual checkup for **Flip Direction**.

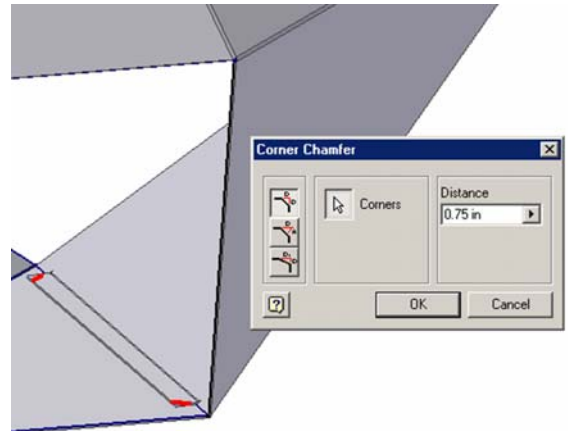
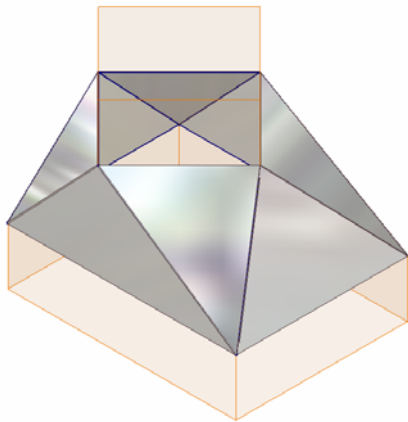


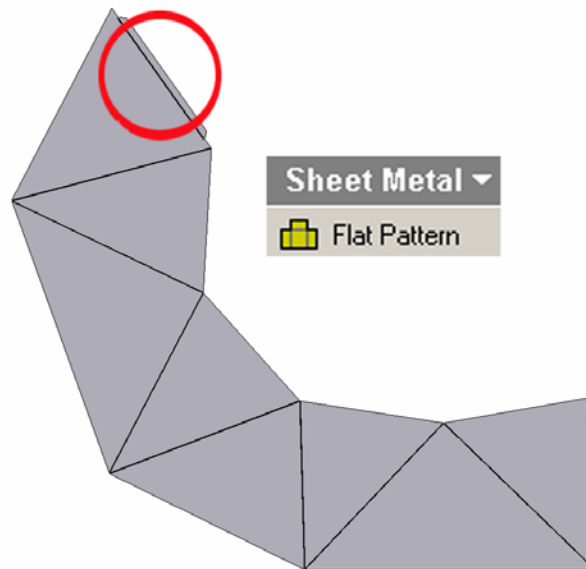
Figure 5-7F: Applying **Corner Chamfers** to both ends of the **Right Triangle Lateral Flange**.

Now, click the **Flat Pattern** button again; the **Right Triangle Lateral Flange** appears in the **Flat Pattern** window.





*Figure 5-7F: The completed folded model.*



*Figure 5-7F: The flat pattern.*

Congratulations! In this *Module*, you have learned the new skills of creating dummy wire-frame models for the design of sheet metal transition pieces with triangulation techniques in Inventor.