

Module 1H: Creating an Ellipse-Based Cylindrical Sheet-metal Lateral Piece

In this Module, we will learn how to create an ellipse-based cylindrical sheet-metal lateral piece with the **Contour Flange** tool. The **Contour Flange** tool can create sheet-metal lateral pieces that are developable by the **Flat Pattern** tool if the **Sketch** features contain open profile made up of straight line or circular arcs created with the **Line** or **Center Point Circle** tools; if the profile is made up of curved line or elliptical arcs created with the **Spline** or **Ellipse** tools, the **Contour Flange** tool can still be used to create the **Contour Flange** 3D feature, however, the **Flat Pattern** tool will not be able to generate the **Flat Pattern** view; instead, it will give the error message shown in *Figure 1H-1A*. Therefore, a “work-around” method will be explored to create an ellipse-based cylindrical sheet-metal lateral piece.

In traditional geometry construction, a fairly accurate approximation of ellipse can be drawn by combining two sets of circular arcs (we can call this approximation method “arcs combination method”), as shown in *Figure 1H-1B*, since the **Contour Flange** features are developable by the **Flat Pattern** tool if the **Sketch** features contain open profile made up of circular arcs created with the **Line** or **Center Point Circle** tools, we will use this “work-around” method to create an ellipse-based cylindrical sheet-metal lateral piece and its **Flat Pattern** view. An ellipse can be considered as a circle rotated to a certain angle (*Figure 1H-1C*); the diameter of the circle that is parallel to the axis of rotation becomes the “major axis” (also called “major axis;” in some textbook, half of the “major diameter” is also called “major radius”) of the ellipse; and the foreshortened diameter that is perpendicular to the axis of rotation is the “minor diameter” (also called “minor axis;” in some textbook, half of the “minor diameter” is also called “minor radius”).

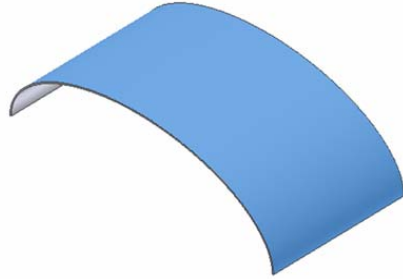
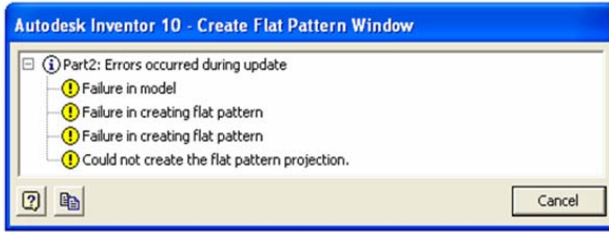

Figure 1H-1A: The error message occurring when the Flat Pattern tool tries to develop an elliptical arc-based cylindrical surface.

In this Module, we will create cylindrical sheet-metal lateral piece with a 36-inch major diameter (18-in major radius) and 18-inch minor diameter (9-inch minor radius) elliptical base.

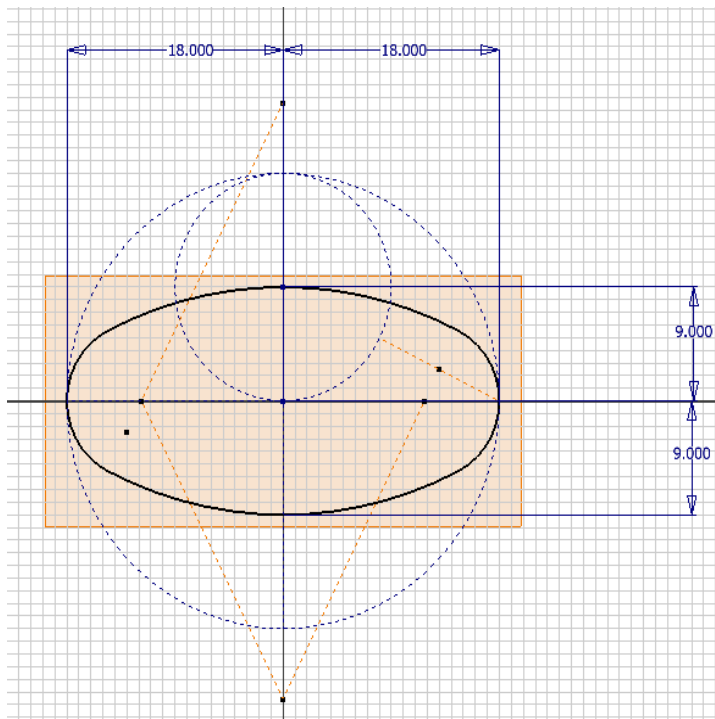

Figure 1H-1B: The fairly accurate approximation of ellipse drawn by combining two sets of circular arcs (the “arcs combination method”).

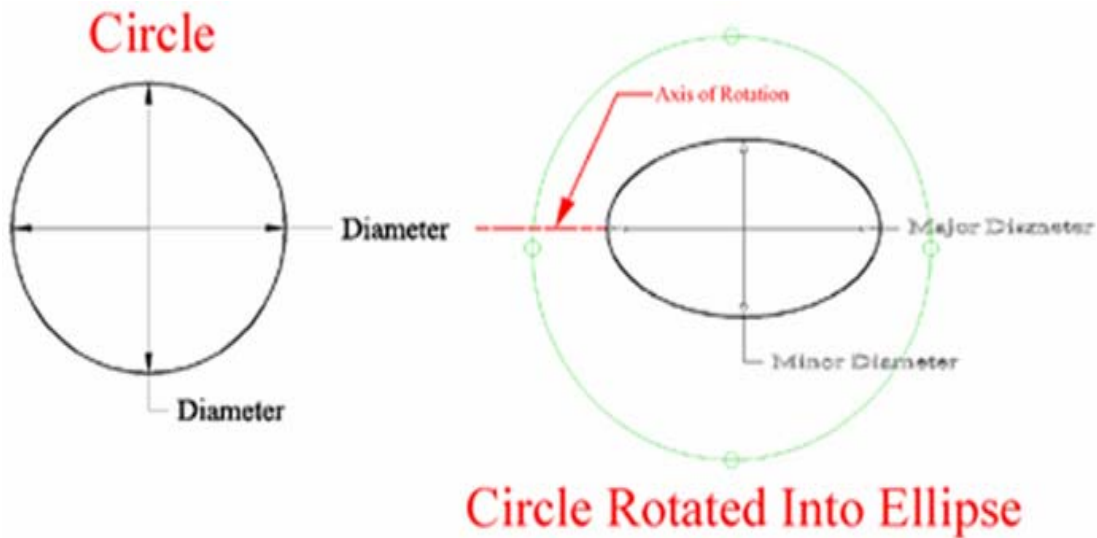

Figure 1H-1C: The relationship between a circle and an ellipse.

Step 1: Construct the elliptical base profile with the arcs combination method

First, we will create a sheet metal file with inch as units. Launch Autodesk Inventor. Create a new sheet metal file (go to the menu **File**→**New**, or click on the **New** icon on **Standard Tool Bar**. The Open window appears. Select the **English** tab; then select the **Sheet Metal (In).ipt** template, click **OK** button (Figure 1H-2A).

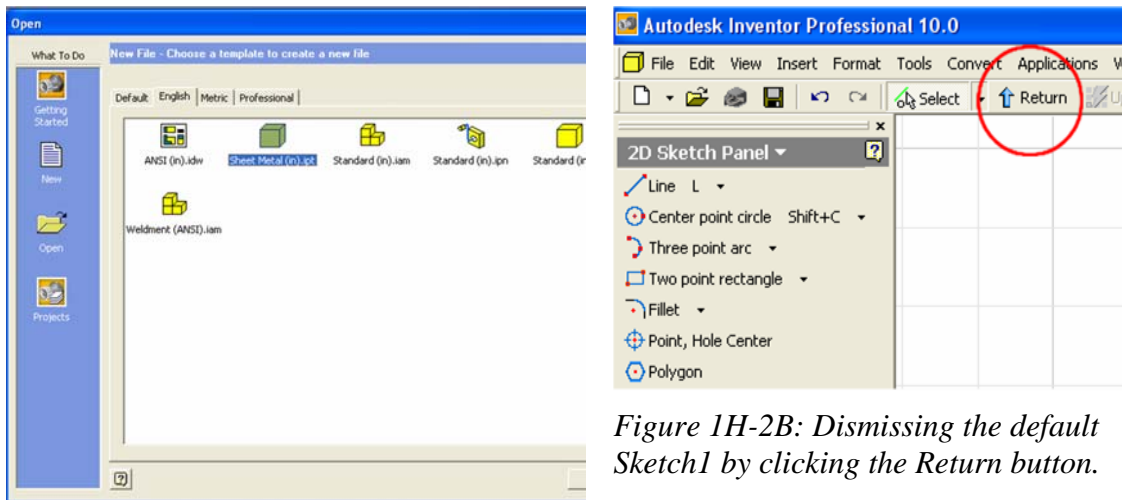

Figure 1H-2A: Starting a new Sheet Metal (In).ipt file.

Figure 1H-2B: Dismissing the default Sketch1 by clicking the Return button.

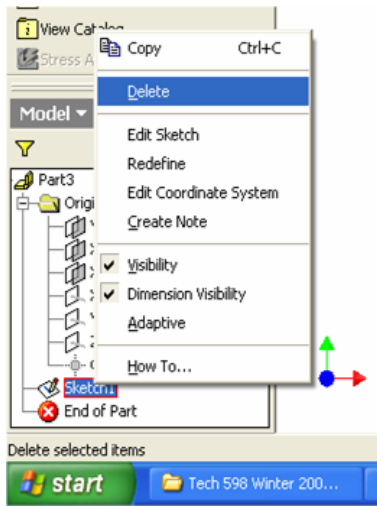

Figure 1H-2C: Deleting the default Sketch1.

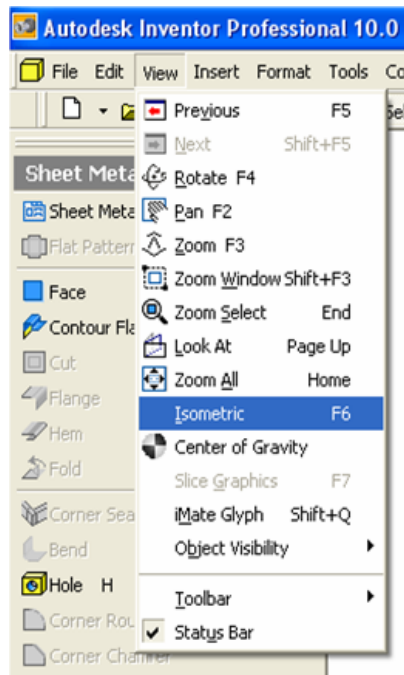

Figure 1H-2D: Switching to Isometric View.

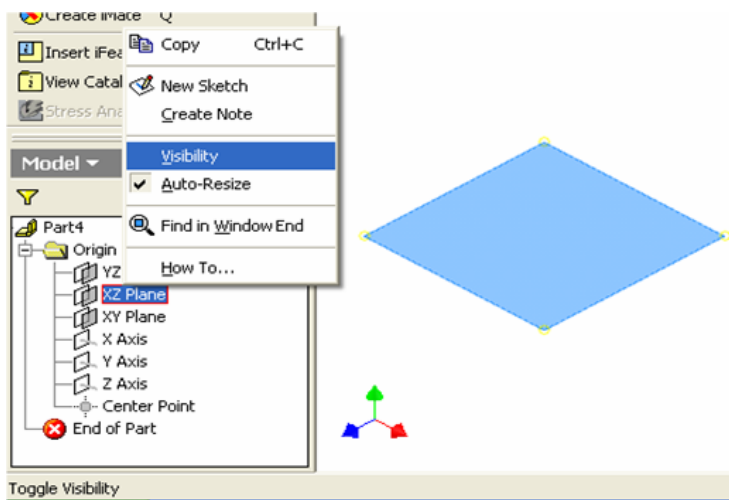

Figure 1H-2E: Turning on the Visibility option.

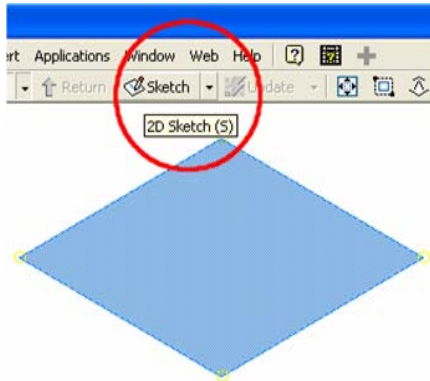

Figure 1H-2F: Starting a new Sketch.

A new sheet metal file opens with two panels docked on the left side of the screen: **2D Sketch** (top) and **Model** (bottom). The **Sketch1** opens automatically on the screen; and **Sketch1** feature appears on the **Model** panel. Click the **Return** key in the **Inventor Standard** tool bar (Figure 1H-2B) to dismiss the **Sketch1** feature.

In the **Model** panel, click the cross on the left of the **Origin** folder to view the **Planes**, **Axis** and **Center Point** features; click-select the **Sketch1** feature and right-click for the shortcut menu and choose the **Delete** option to delete it (Figure 1H-2C). Next, go to the View→Isometric menu to switch to an isometric view (Figure 1H-2D). Next, select the **XZ Plane**, then right-click to open the short cut menu and check the **Visibility** option (Figure 1H-2E). Next, click-select the **XZ Plane** and then the **Sketch** button on the **Inventor Standard** tool bar to start a new sketch (Figure 1H-2F); **Sketch2** feature appears in the **Model** panel; highlight the **Sketch2** name and type *Base Profile* to rename the feature.

Next, click-select the **XZ Plane** and then the **Look At** tool button in the **Inventor Standard** tool bar (Figure 1H-2G, left) to switch to an orthographic normal view (Figure 1H-2G, right). Now, we are ready to start the elliptical base profile.

Click-select the **Project Geometry** tool from the **2D Sketch** tool panel and then the **Center Point** from the **Model** panel to project it onto the *Base Profile Sketch*; a green dot appears on the center of the *Base Profile Sketch*; next, select the **Line** tool from the **2D Sketch** tool panel and create two horizontal “major radius” lines and two vertical “minor radius” lines, all from the projected **Center Point**, right-clicking for the shortcut menu and choose the **Restart** option each time one line is created to create the subsequent line (Figure 1H-3A); next, select the **General Dimensions** tool to apply an 18-inch linear horizontal dimension to both horizontal lines, and a 9-inch linear vertical dimension to the vertical lines (Figure 1H-3B); next, select the **Center Point Circle** tool,

move the cursor closer to the projected **Center Point**, click once when the green dot snap indicator appears to establish the center point of the circle, and then move the cursor to the left endpoint of the left horizontal line (point “A”), click once when the green dot snap indicator appears to establish the radius of the circle (the “large construction circle;” see *Figure IH-3C*).

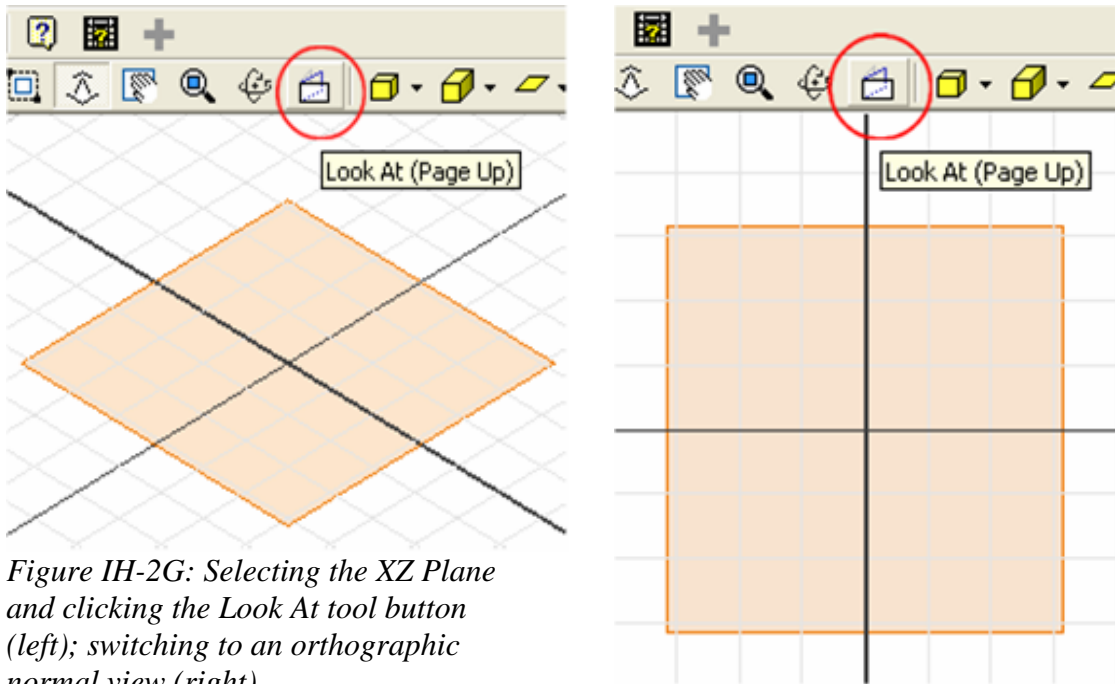

Figure IH-2G: Selecting the XZ Plane and clicking the Look At tool button (left); switching to an orthographic normal view (right).

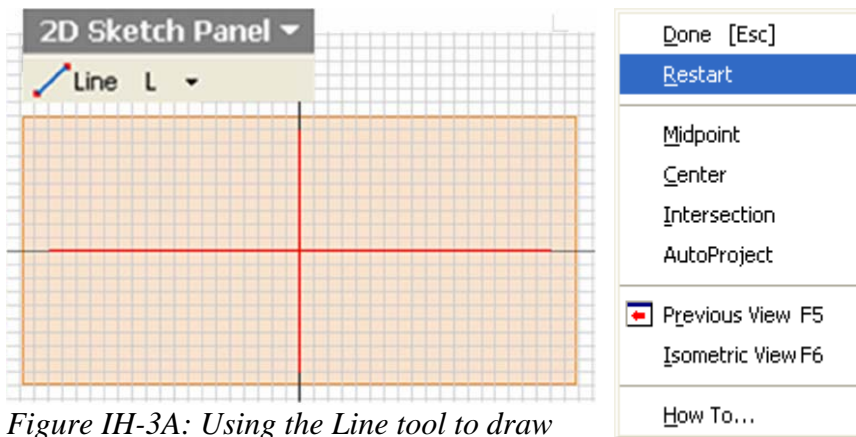

Figure IH-3A: Using the Line tool to draw two vertical lines and two horizontal lines.

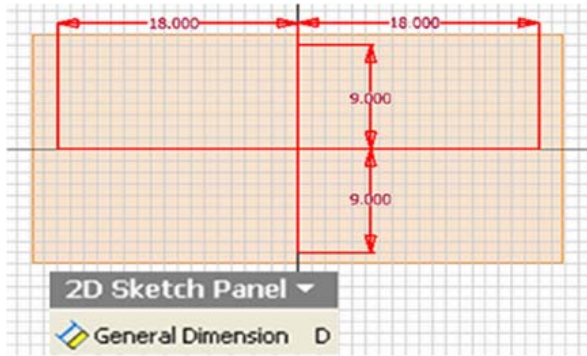

Figure IH-3B: Applying linear dimensions.

Next, use the **Line** tool to create the inclined line segment BC connecting the right endpoint of the right horizontal “major radius” line and the top endpoint of the top vertical “minor radius” line (Figure IH-3D); then create the vertical line starting at point B upward beyond the “construction circle” (the “vertical construction line;” Figure IH-3E). Next, use the **Trim** tool to trim off excessive line segment beyond the “construction circle” (Figure IH-3F). Next, use the **Center Point Circle** tool to create the small construction circle (Figure IH-3G) centered at point B (the top endpoint of the top “minor radius” line) and with the radius established at point D (the top endpoint of the “vertical construction line”); this “small construction circle” intersect the inclined line BC at point E.

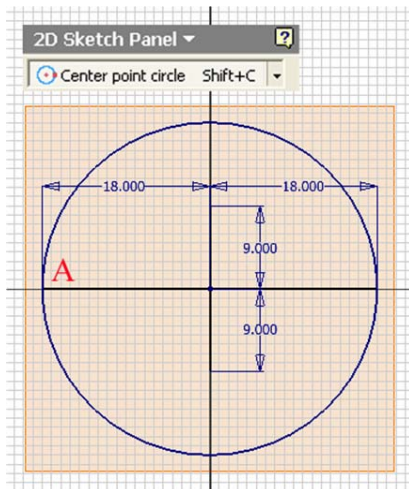

Figure IH-3C: Creating the “large construction circle” with the radius established at point A.

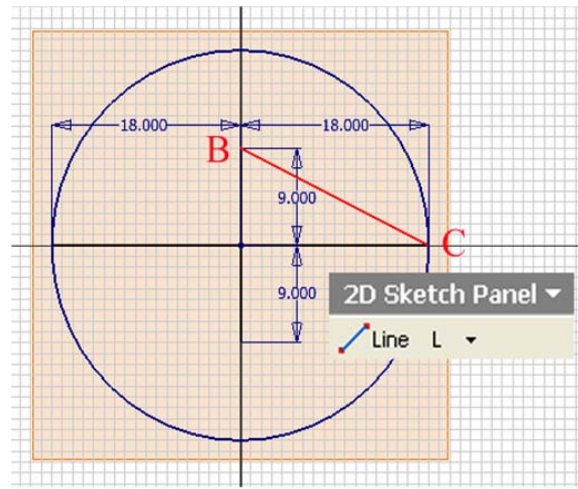

Figure IH-3D: Creating the inclined line segment BC.

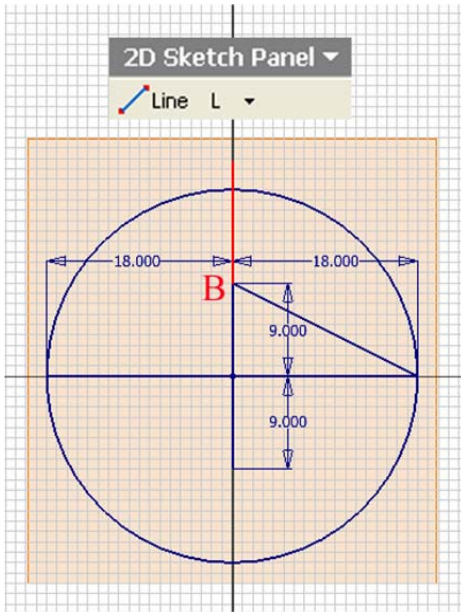

Figure 1H-3E: Creating the “vertical construction line.”

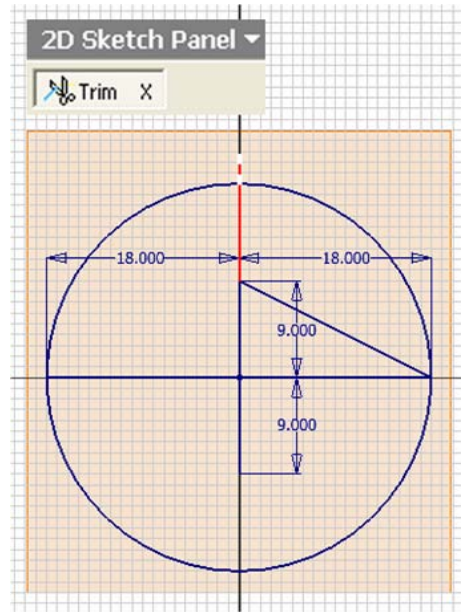

Figure 1H-3F: Trimming off the excessive line segment beyond the “construction circle.”

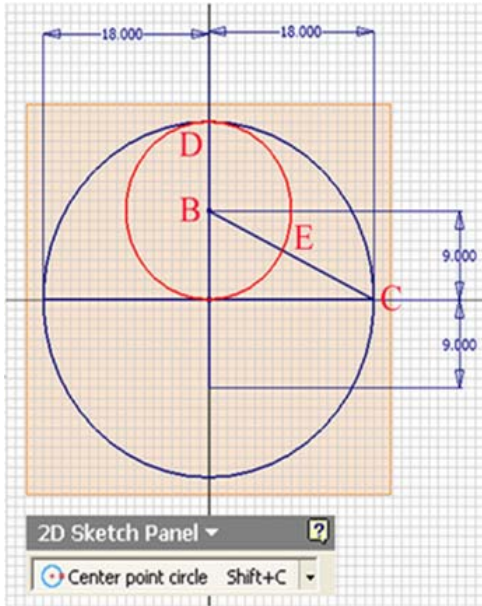

Figure 1H-3G: Creating the small construction circle.

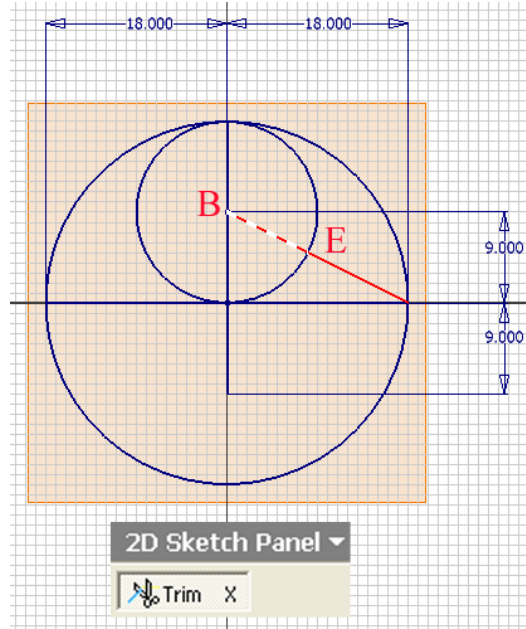

Figure 1H-3H: Trimming off line segment BE.

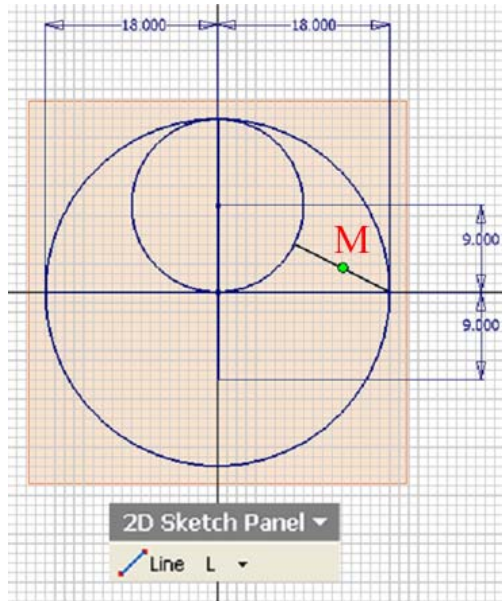

Figure 1H-3J: The green dot midpoint snap indicator.

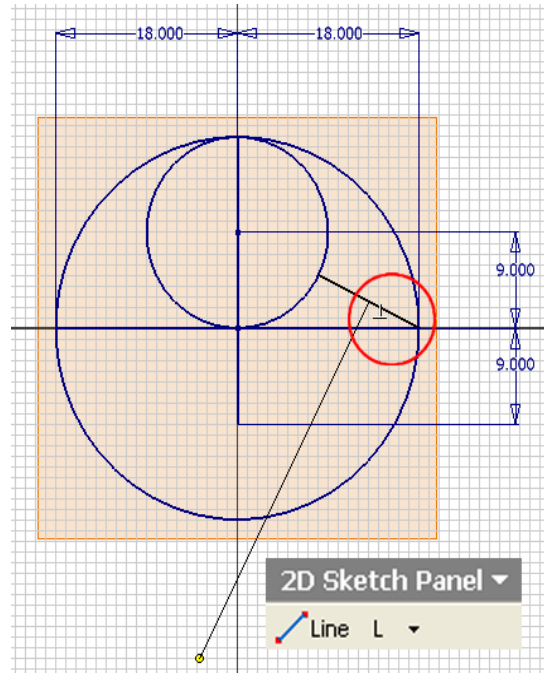

Figure 1H-3K: Creating the “perpendicular bisector line” of the inclined line BC.

Next, use the **Trim** tool to trim off line segment BE as shown in *Figure 1H-3H*. Next, select the **Line** tool, move the cursor to the midpoint M and click once at the appearance of the green dot midpoint snap indicator (*Figure 1H-3J*), move away downward and leftward beyond the bottom vertical “minor radius” line and click once at the appearance of the perpendicular constraint indicator (“ \perp ” symbol inside the red circle, as shown in *Figure 1H-3K*); this is the “perpendicular bisector line” of the inclined line BC. Next, use the **Line** tool to create the vertical line starting at the bottom endpoint of the bottom “minor radius” line and intersecting the perpendicular bisector line (the “extension line;” as shown in *Figure 1H-3L*). Next, use the **trim** tool to trim off the excessive line segments beyond the point of intersection (*Figure 1H-3M* and *Figure 1H-3N*).

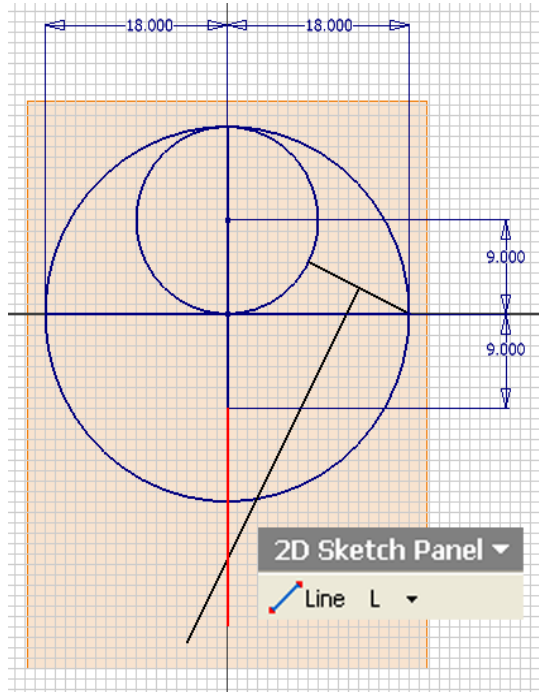

Figure 1H-3L: Creating the vertical line.

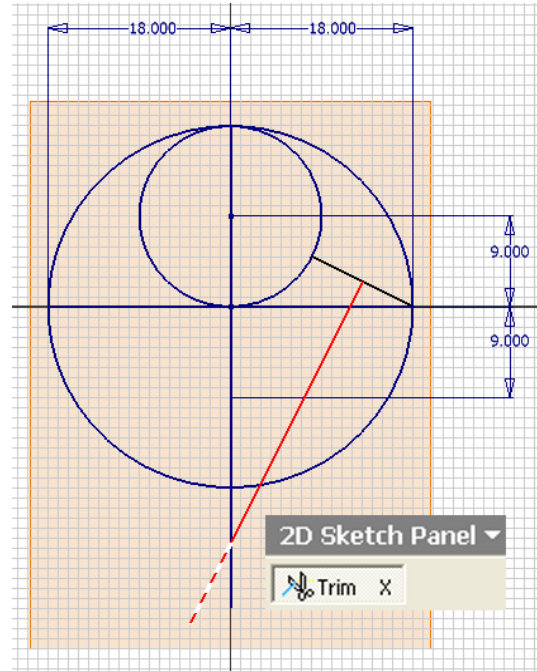

Figure 1H-3M: Trimming off the excessive line segment.

Next, select the **Mirror** tool; click the **Select** button in the tool's dialog window and then click-select the "perpendicular bisector line;" click the **Mirror Line** button in the tool's dialog window and then click-select the top "minor radius" line (Figure 1H-3P); click the **OK** button in the tool's dialog window to create the mirrored line (Figure 1H-3Q). Use the **Mirror** tool again; click the **Select** button in the tool's dialog window and then click-select the mirrored line and the "extension line;" click the **Mirror Line** button in the tool's dialog window and then click-select the left "major radius" line (Figure 1H-3R); click the **OK** button in the tool's dialog window to create the mirrored lines (Figure 1H-3S). Next, window-select all of the lines drawn so far and click the **Construction** tool button in the **Inventor Standard** tool bar to change the line **Style** to **Construction** (Figure 1H-3T).

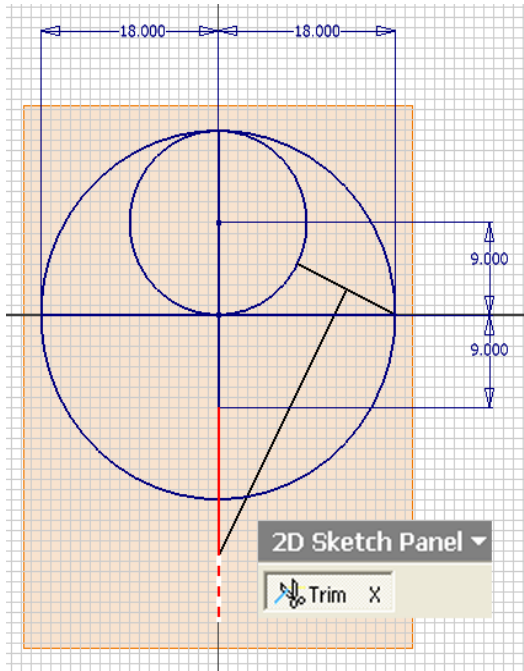

Figure 1H-3N: Trimming off the excessive line segment.

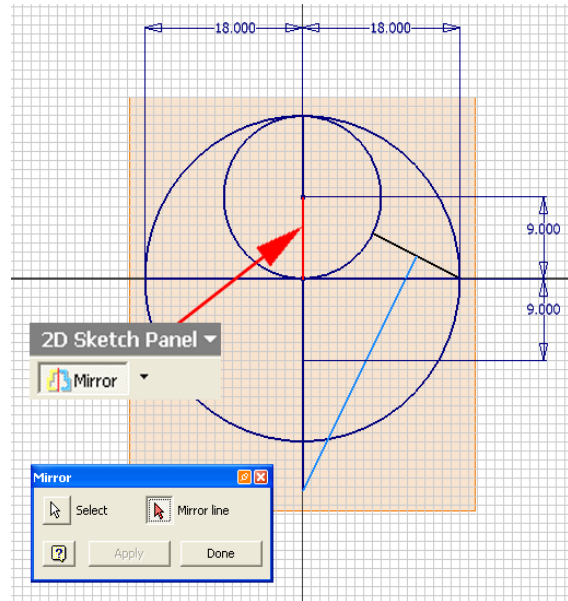

Figure 1H-3P: The Mirror tool's dialog window.

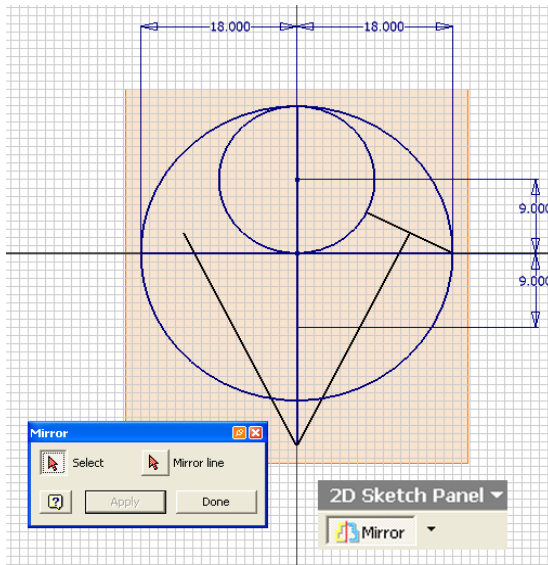

Figure 1H-3Q: Creating the mirrored line of the "perpendicular bisector line" on the left side of the top "minor radius" line.

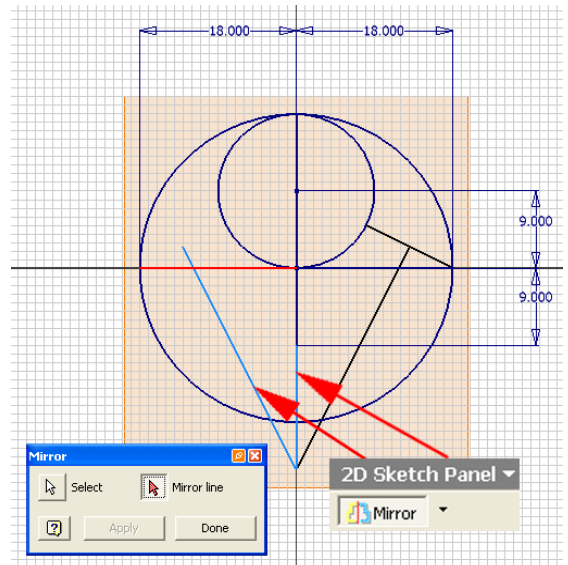

Figure 1H-3R: Selecting the lines to be mirrored and the Mirror line.

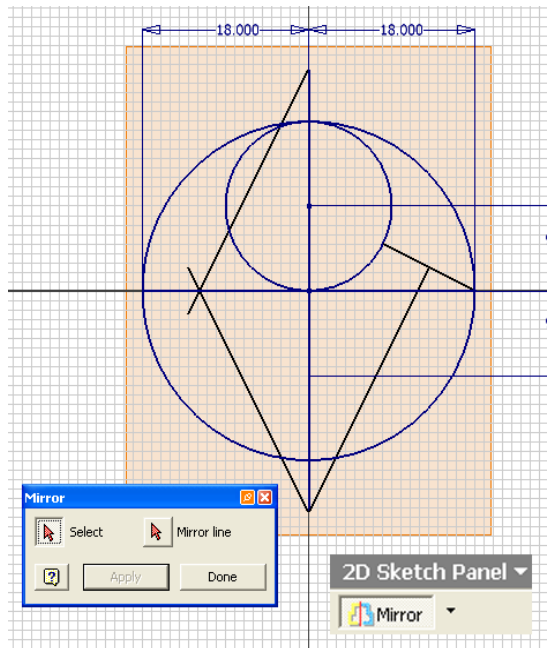

Figure 1H-3S: Creating the mirrored lines.

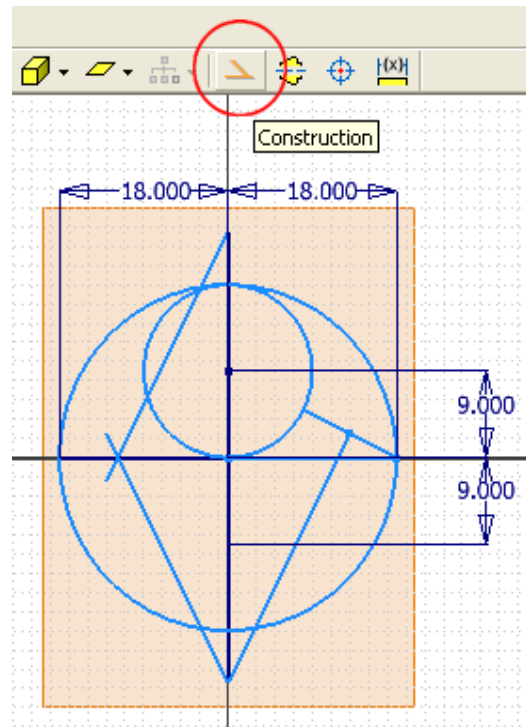

Figure 1H-3T: Changing the line Style to Construction.

Next, select the **Trim** tool to trim off excessive line segments (Figure 1H-3U to Figure 1H-3W) and to leave a clean set of construction lines (Figure 1H-3X).

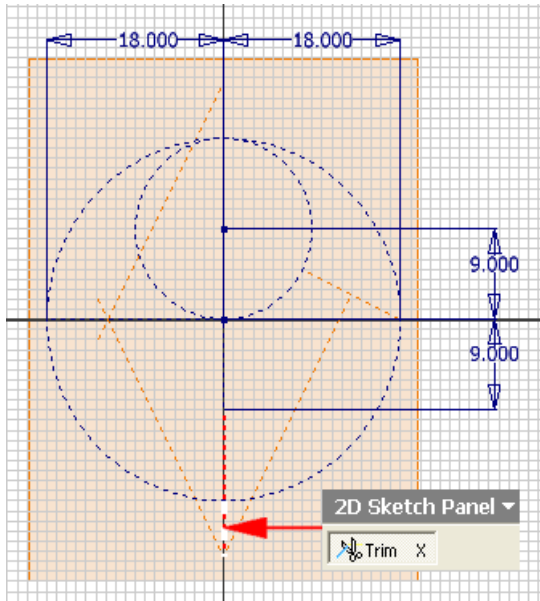

Figure 1H-3U: Trimming off excessive line segments.

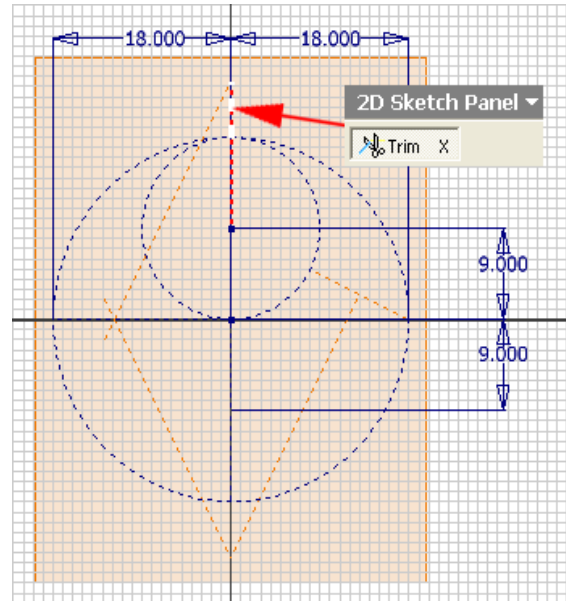

Figure 1H-3V: Trimming off excessive line segments.

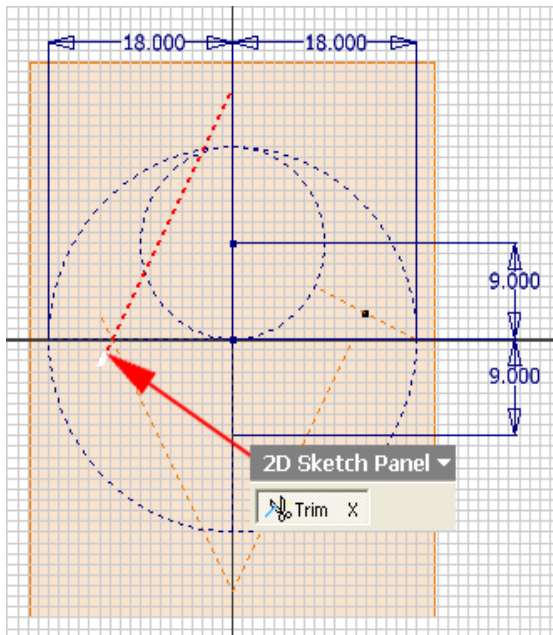

Figure 1H-3W: Trimming off excessive line segments.

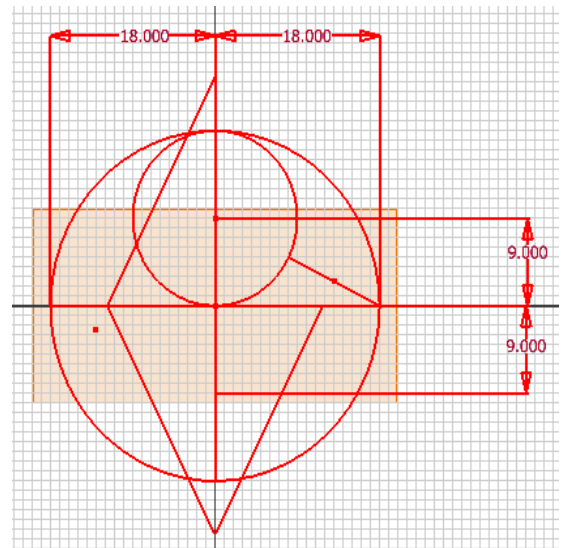

Figure 1H-3X: Leaving a clean set of construction lines.

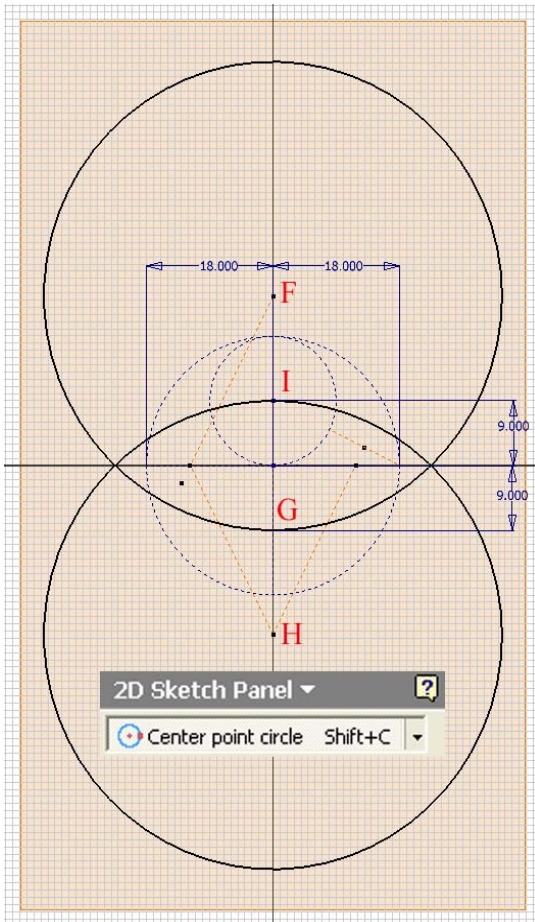

Figure 1H-4A: The “large circles.”

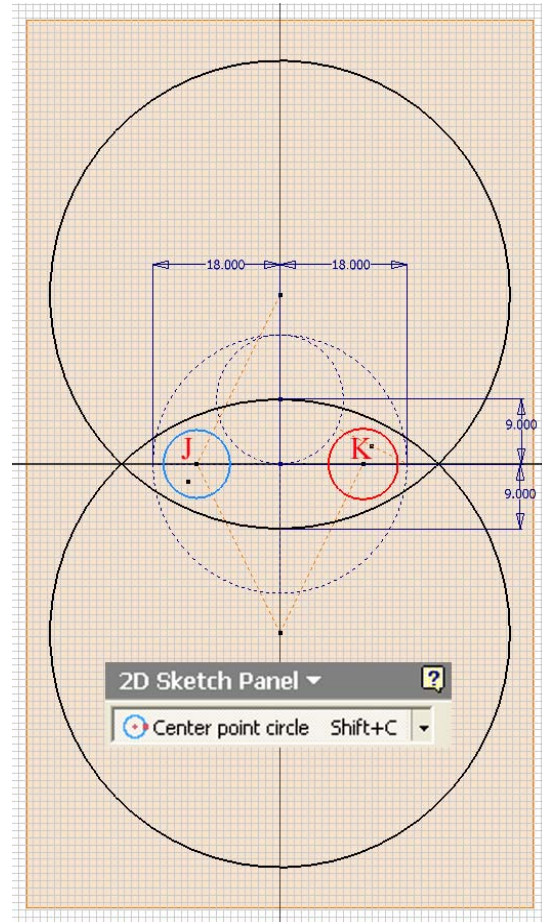

Figure 1H-4B: The “small circles.”

Next, select the **Center Point Circle** tool to create a circle centered at the point F and with the radius established at the point G, and another circle centered at the point H and with the radius established at the point I (the “large circles;” as shown in *Figure 1H-4A*). Next, use the **Center Point Circle** tool again to create two circles centered at the points J and K (the “small circles;” as shown in *Figure 1H-4B*). Next, select the **Tangent** tool, click-select one of the “large circles” and then one of the “small circles” to enlarge the size of the “small circle” so that it becomes tangent to both “large circles” (*Figure 1H-4C*); repeat the some process for another “small circle” (*Figure 1H-4D*).

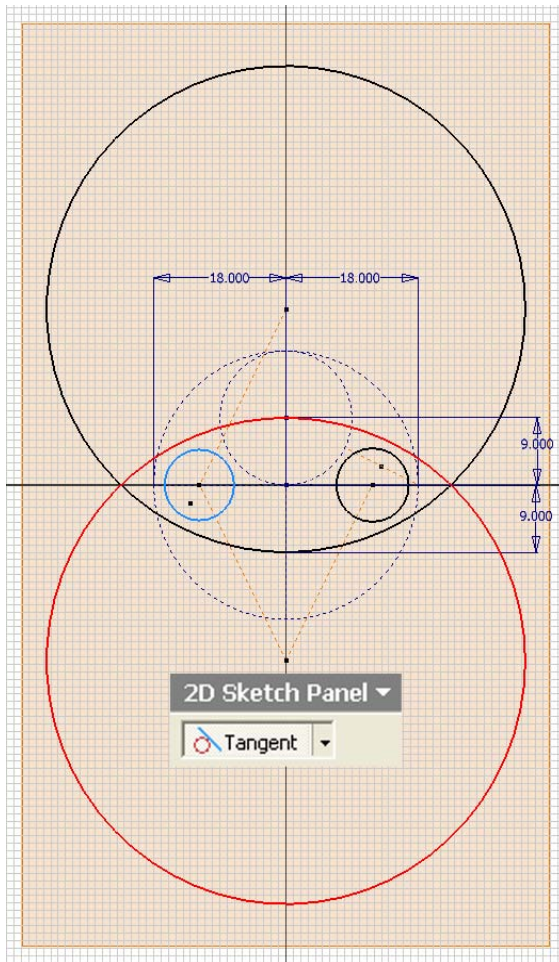

Figure 1H-4C: Enlarging the “small circle” to tangency with the two “large circles.”

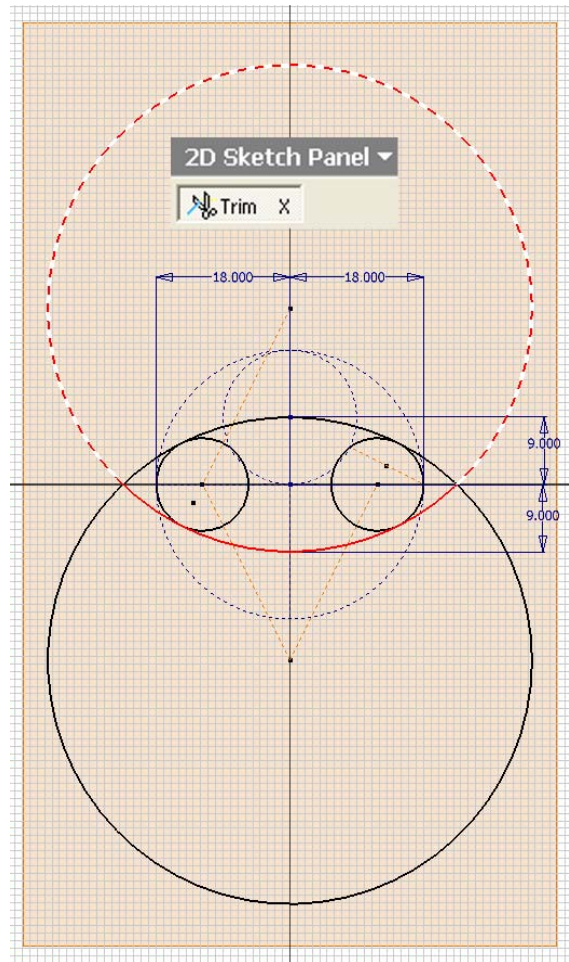

Figure 1H-4D: Enlarging the other “small circle” to tangency with the two “large circles.”

Next, select the **Trim** tool to trim off the excessive arc segments of “large circles” and “small circles” (Figure 1H-4E through Figure 1H-4G), so as to leave the approximate elliptical profile, and use the **Zoom Window** tool to zoom in the red circled area, as shown in Figure 1H-4H.

Next, create a tiny gap in the closed approximate elliptical profile so that the **Flat pattern** tool can generate the **Flat Pattern** view after the **Contour Flange** lateral piece is created; use the **Center Point Circle** tool to create a small circle centered at the left endpoint of the left “major radius” line, and use the **General Geometry** tool to apply an diameter dimension of 0.001-inch (Figure 1H-4J); use the **Zoom Window** tool to zoom in several times if needed.

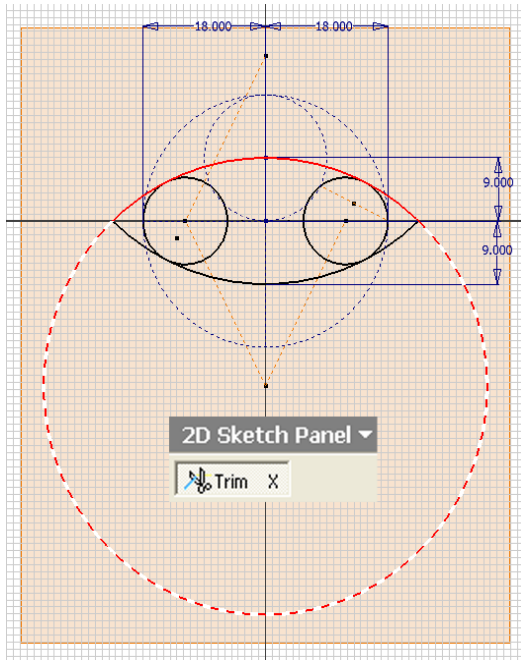

Figure 1H-4E: Trimming off the excessive arc segments of “large circles.”

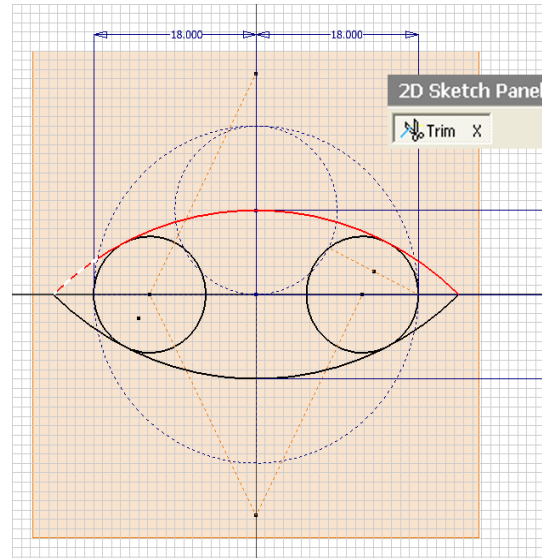

Figure 1H-4F: Trimming off the excessive arc segments of “large circles.”

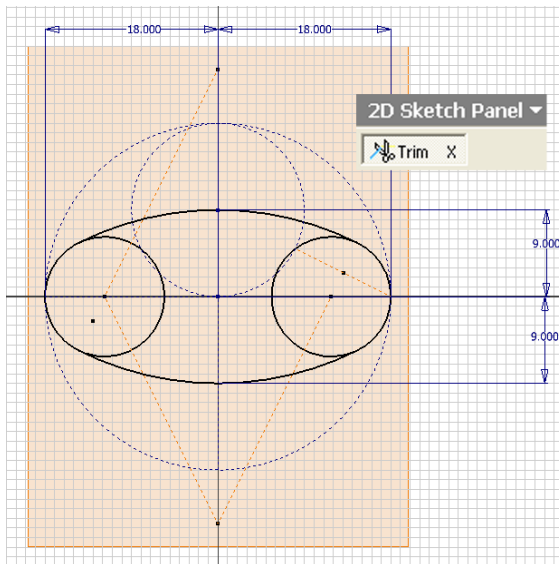

Figure 1H-4G: The excessive arc segments of the “small circles” to be trimmed off.

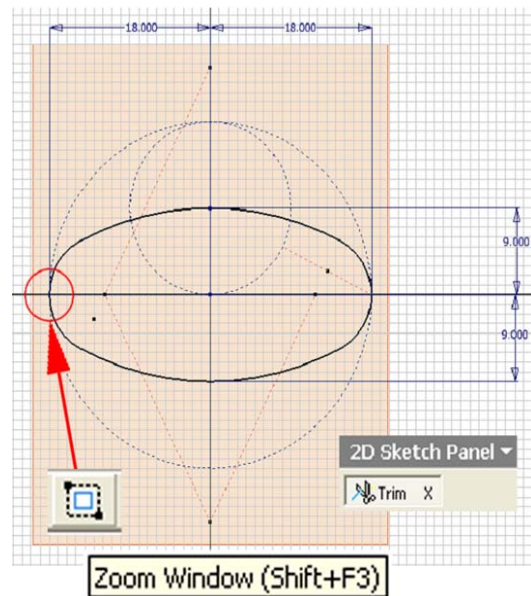

Figure 1H-4H: The approximate elliptical profile.

Next, select the **Trim** tool to trim off the tiny segment of arc as shown in *Figure 1H-4K*; right-click for the shortcut menu and choose the **Done** option to exit the **Trim** tool (*Figure 1H-4L*), click-select the tiny construction circle and press the **Delete** key on the keyboard to delete it (*Figure 1H-4M*). Next, click the **Return** button on the **Inventor Standard** tool bar; go to the **View**→**Isometric** menu to switch to an isometric view (*Figure 1H-4N*). In the **Model** panel, select the **Sketch1** feature, highlight the name and retype *Base Profile* to rename it. Now, start saving the file. Press **Ctrl** and **s** keys simultaneously to save the file as *Tut-Elliptical Cylinder.ipt* with **Part File (*.ipt)** for **Save As Type** field, in a convenient directory location, in a new folder to be created and named *Tut-Elliptical Cylinder* in the **Save As** window in a convenient directory location (*Figure 1H-4P*). Save often, at least at the end of each step.

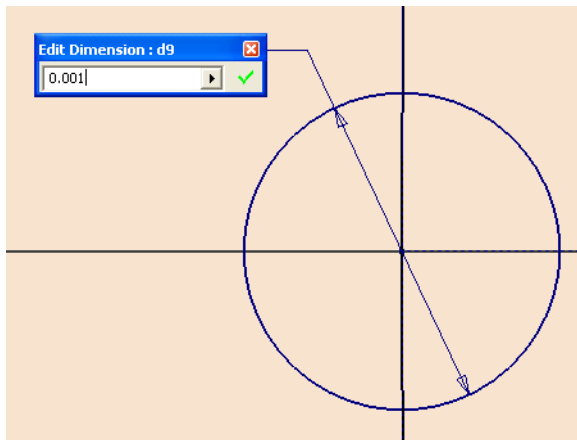

Figure 1H-4J: Creating the tiny construction circle for the gap.

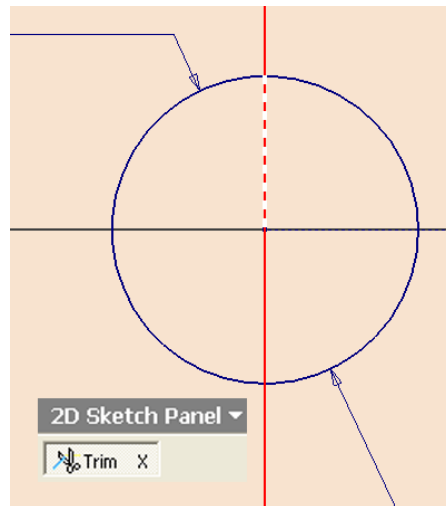

Figure 1H-4K: Trimming a small gap.

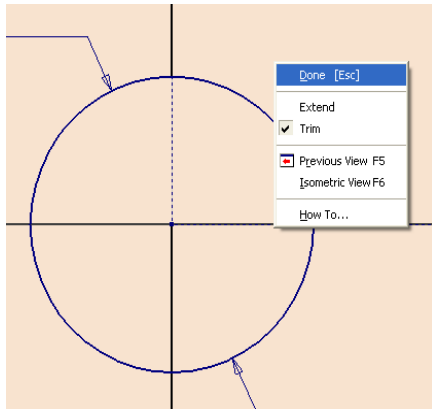

Figure 1H-4L: Exiting the Trim tool.

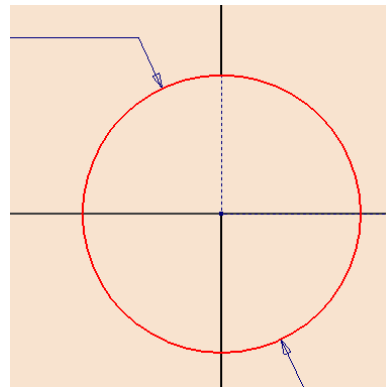

Figure 1H-4M: Deleting the tiny construction circle.

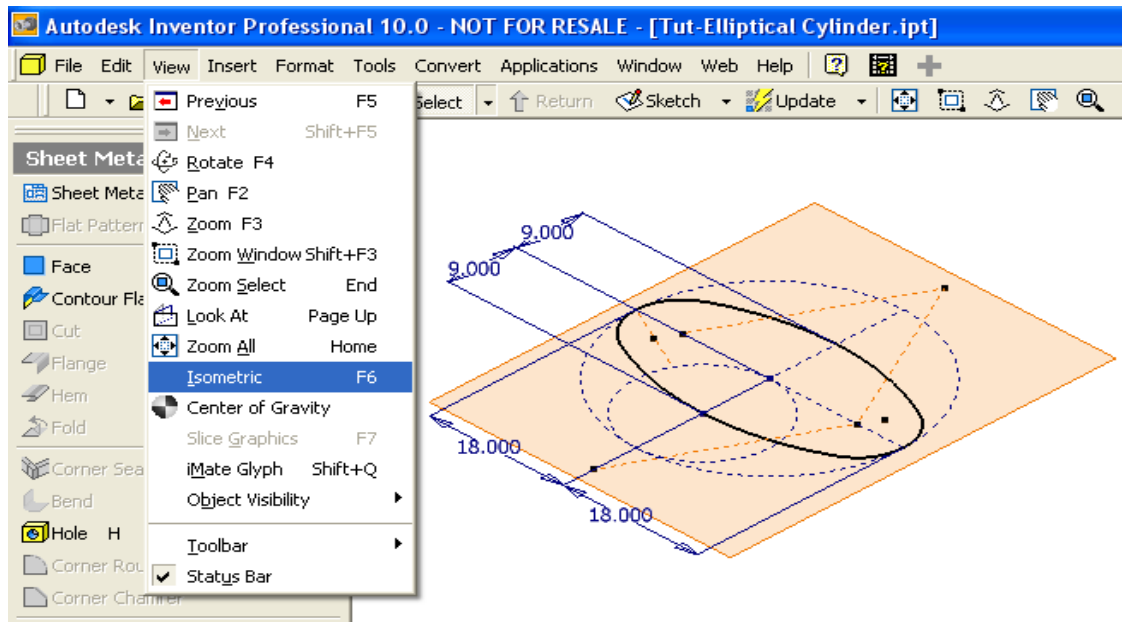

Figure 1H-4N: Switching to an isometric view.

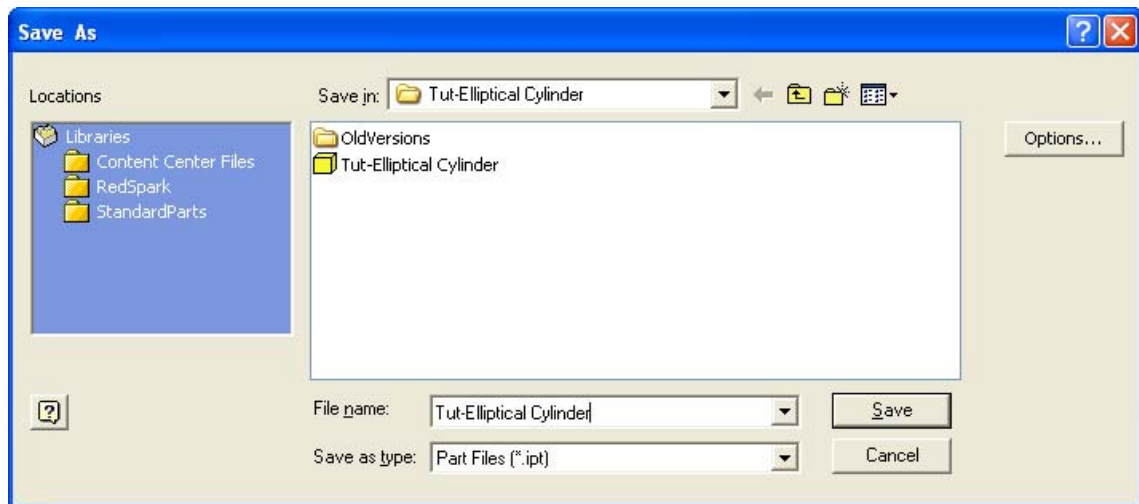

Figure 1H-4P: Saving the file.

Step 2: Create the elliptical-based cylinder with the Contour Flange tool

Next, switch to the **Sheet Metal Features** tool bar and select the **Contour Flange** tool; click the **Profile** button in the **Contour Flange** tool's dialog window and click-select the elliptical profile from the screen; type *24 in* in the **Distance** text field (*Figure 1H-5A*); the green outlines of the **Contour Flange** feature appears on the screen; use the **Zoom Window** tool to zoom in the leftmost area and click the **Offset** button in the **Contour Flange** tool's dialog window until the green outline of the **Contour Flange** feature indicates that it is projected inwardly (*Figure 1H-5B*); click the **OK** button to create the **Contour Flange** feature and rename it *Elliptical Cylinder* in the **Model** panel.

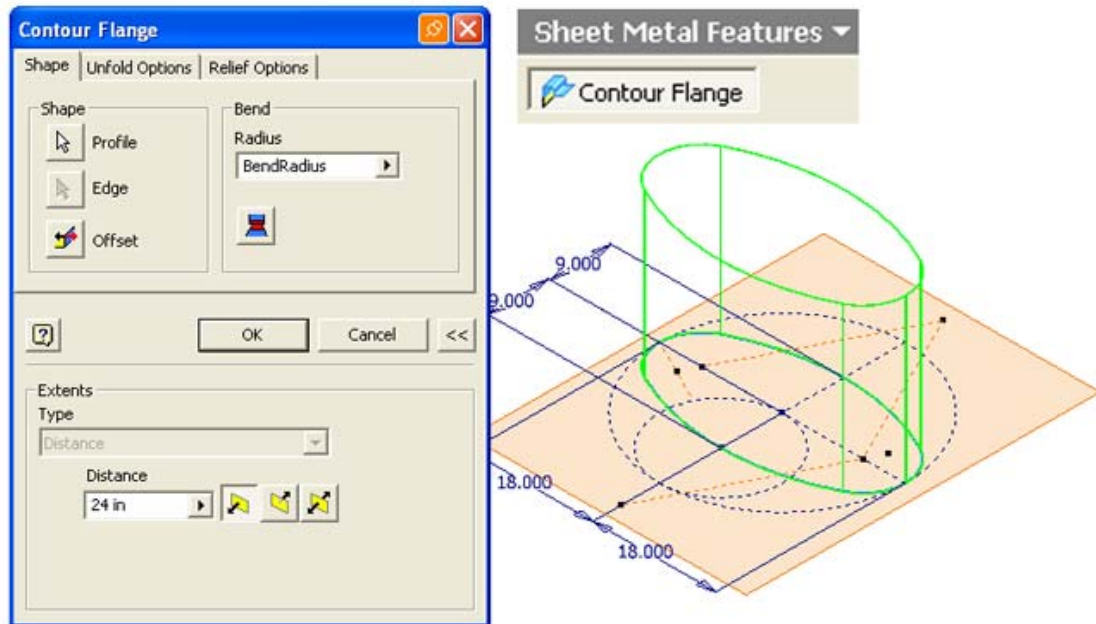
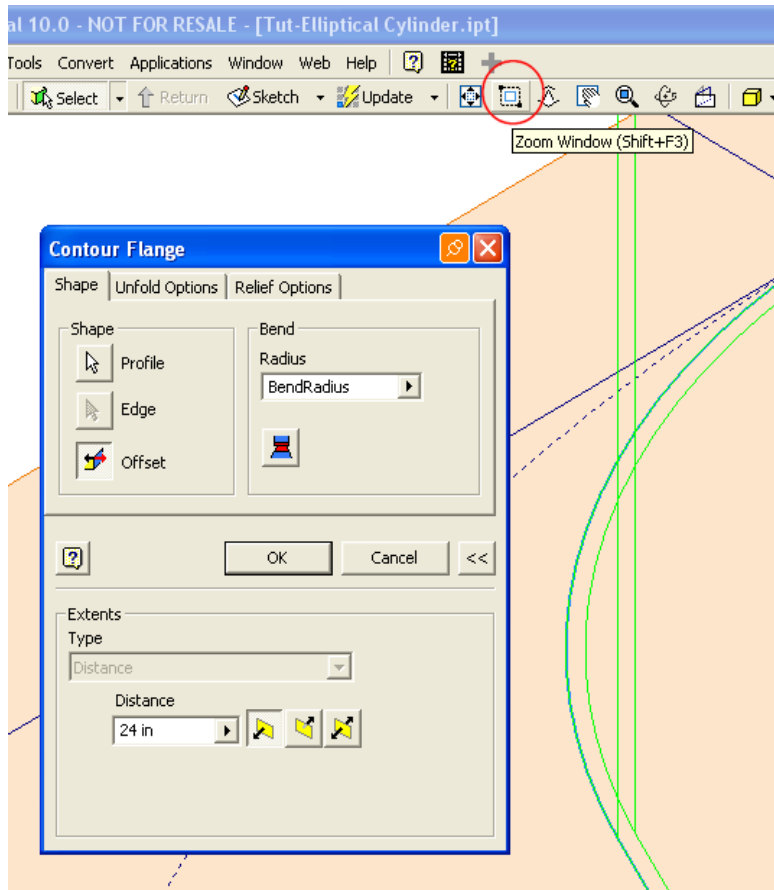

Figure 1H-5A: Selecting the elliptical profile and typing the Distance value.



*Figure 1H-5B:
Zooming in the leftmost
area and clicking the
Offset button in the
Contour Flange tool's
dialog window until the
green outline of the
Contour Flange feature
indicates that it is
projected inwardly.*

Step 3: Truncate the elliptical cylinder

Next, select the **XY Plane** feature from the **Model** panel (*Figure 1H-5C*) and click the **Sketch** button from the **Inventor Standard** tool bar to start a new **Sketch** feature; rename the **Sketch** feature as *Truncation Profile* in the **Model** panel; click the **Look At** button in the **Inventor Standard** tool bar and then the to switch the *Truncation Profile* to an orthographic normal view. Next, select the **Project Geometry** button and click the top horizontal edge of the cylindrical piece (*Figure 1H-5D*); select the projected line and click the **Construction** tool and change its line **Style**. Next, select the **Center Point Circle** tool to create a circle centered at the midpoint of the projected top horizontal edge line; and use the **General Dimension** tool to apply a 18-inch diameter dimension to the circle. Click the **Return** button to finish the sketch.

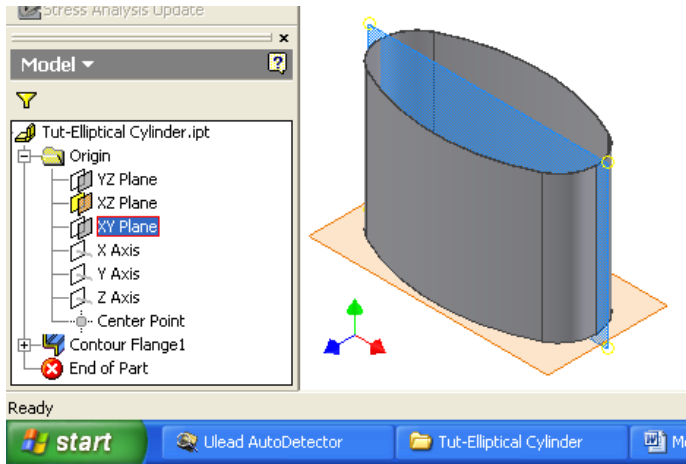

Figure 1H-5C: Select the XY Plane feature from the Model panel to start a new Sketch.

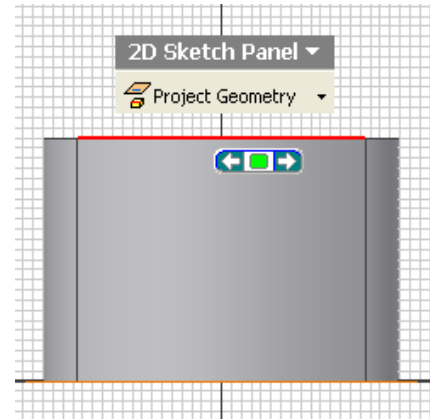

Figure 1H-5D: Switching to an orthographic normal view with the Look At tool and projecting the top horizontal edge with the Project Geometry tool.

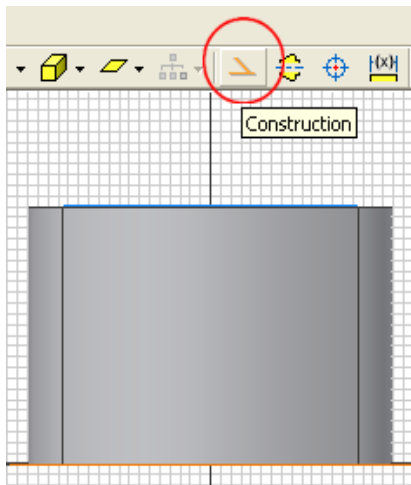

Figure 1H-5E: Changing the line Style to Construction.

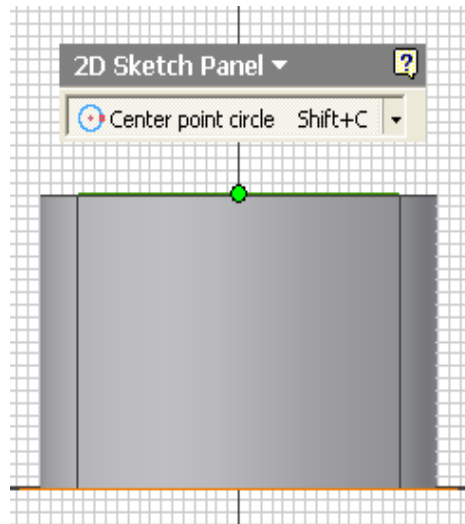

Figure 1H-5F: Starting to create a circle with the help of the midpoint snap indicator.

Next, switch to the **Part Features** tool panel by clicking the downward-pointing triangle to open up a pull-down list and to select the option (Figure 1H-5H); select the **Extrude** tool, in the tool's dialog window, select the **Cut** option for **Type** and **Midplane**

option for **Direction** (red circled); click the **Profile** button and click-select the circular profile; select the **All** option from the **Extents** pull-down menu; click the **OK** button to create the **Extrude** feature (*Figure 1H-5J*) and rename it as *Truncation* in the **Model** panel.

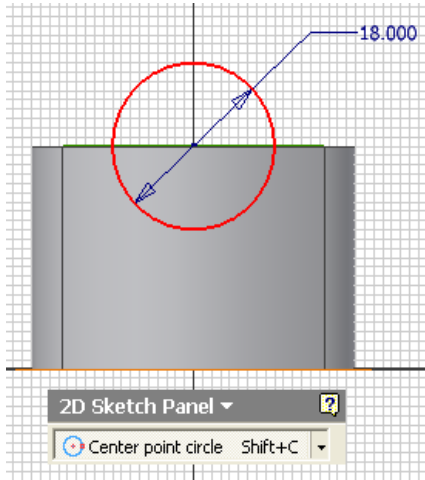

Figure 1H-5G: Creating and dimensioning the circle.

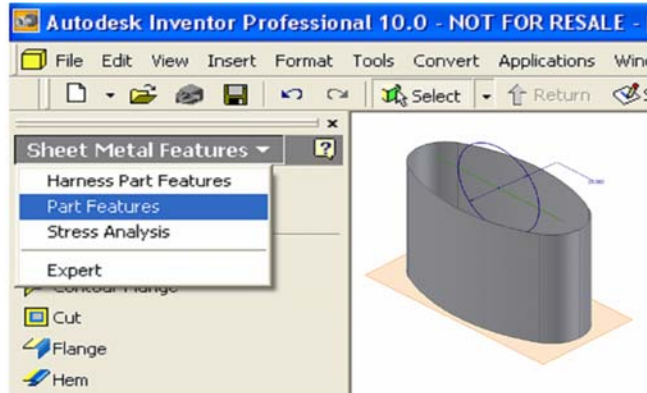

Figure 1H-5H: Switch to the Part Features tool panel.

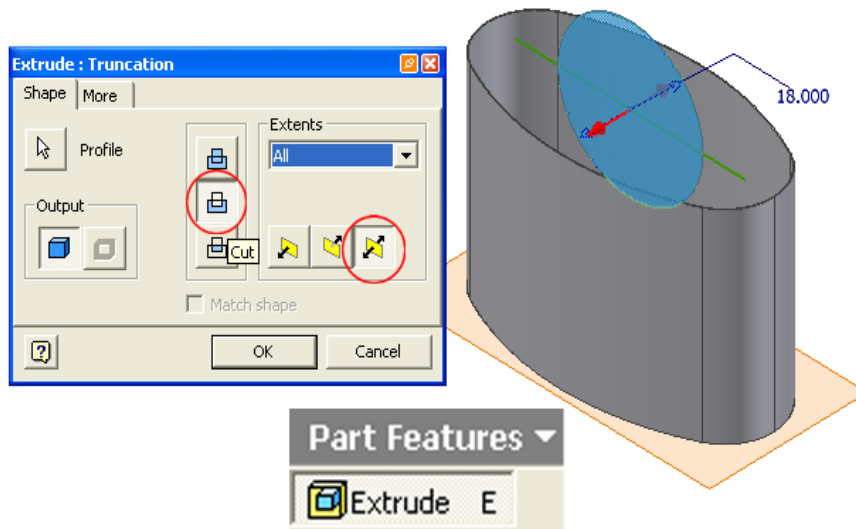

Figure 1H-5J: Creating the Extrude Cut feature.

Next, switch to the **Sheet Metal Features** (*Figure 1H-5K*); click-select the frontal outer surface of the lateral piece (*Figure 1H-5L*) and click the **Flat Pattern** tool button to create the **Flat Pattern** view (*Figure 1H-6A*). If desirable, apply a colorful material

rendering by selecting a material type from the pull-down menu on the **Inventor Standard** tool bar (Figure 1H-6B); the **Flat Pattern** view automatically updates (Figure 1H-6C).

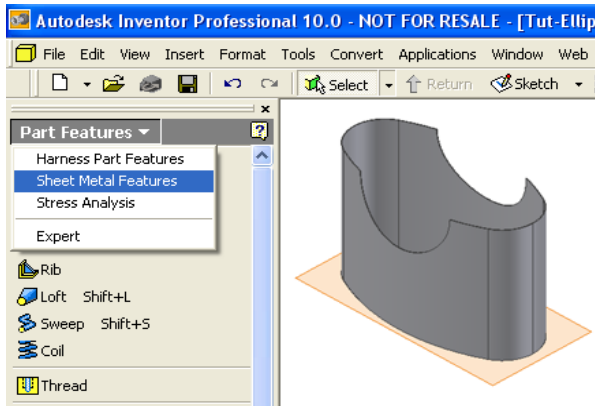

Figure 1H-5K: Switching to the Sheet Metal Features.

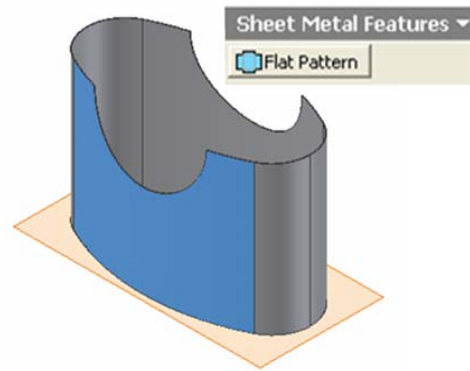

Figure 1H-5L: Selecting the frontal outer surface of the truncated elliptical cylinder for Flat Pattern view generation.

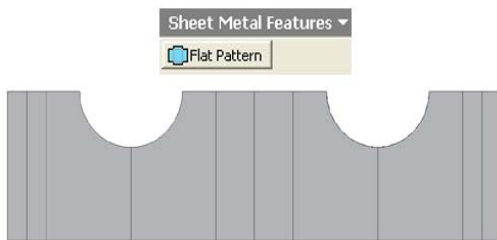

Figure 1H-6A: The Flat Pattern view.

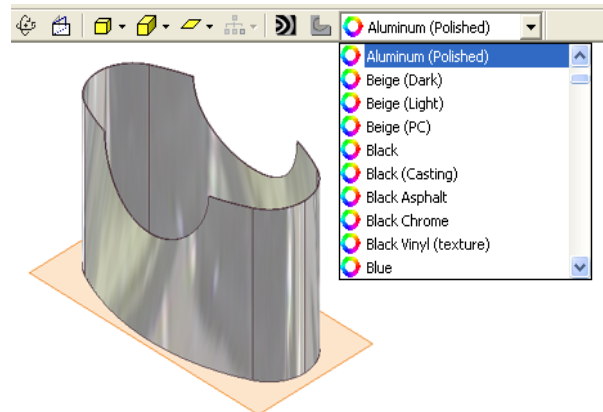

Figure 1H-6B: Applying an Aluminum (Polished) material rendering.

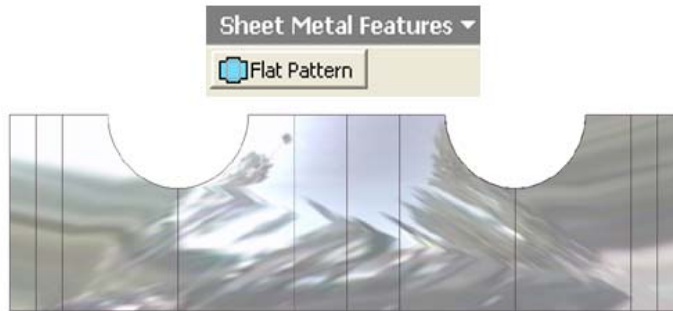

Figure 1H-6C (left): The Flat Pattern view automatically updating to the assigned material rendering.

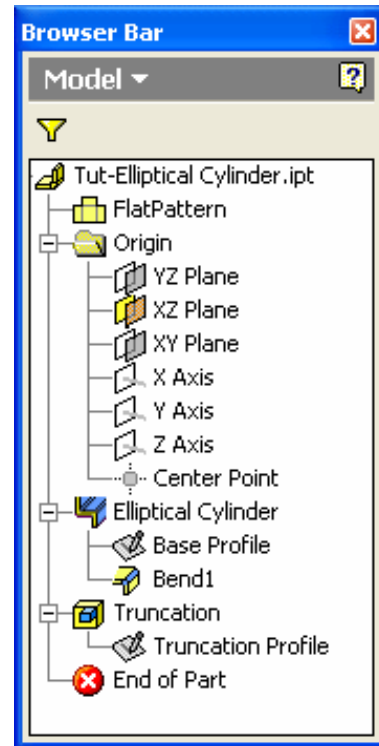

Figure 1H-6D (right): The Model panel feature list.

Congratulations! In this Module, you have learned how to create a truncated elliptical cylinder sheet-metal part and its **Flat Pattern** view.